

Instructions for Use

Performer[®]

Dental Chair, Delivery System, Assistant's Instrumentation,
Support Center with Cuspidor, and Light

Copyright

Copyright 2021 A-dec, Inc. All rights reserved.

A-dec, Inc. makes no warranty of any kind with regard to this material, including, but not limited to, the implied warranties of merchantability and fitness for a particular purpose. A-dec, Inc. shall not be held liable for any errors contained herein or any consequential or other damages concerning the furnishing, performance or use of this material. The information in this document is subject to change without notice. If you find any problems in the documentation, please report them to us in writing. A-dec, Inc. does not warrant that this document is error-free.

No part of this document may be copied, reproduced, altered, or transmitted in any form or by any means, electronic or mechanical, including photocopying, recording, or by any information storage and retrieval system, without prior written permission from A-dec, Inc.

Trademarks and Additional Intellectual Property Rights

A-dec, the A-dec logo, A-dec Inspire, Cascade, Century Plus, Continental, Decade, ICX, ICV, Performer, Preference, Preference Collection, Preference ICC, Radius, and reliablecreativesolutions are trademarks of A-dec, Inc. and are registered in the United States and other countries. A-dec 500, A-dec 400, A-dec 300, A-dec 200, and EasyFlex are also trademarks of A-dec, Inc. None of the trademarks or trade names in this document may be reproduced, copied, or manipulated in any manner without the express, written approval of the trademark owner.

Certain touchpad symbols and icons are proprietary to A-dec, Inc. Any use of these symbols or icons, in whole or in part, without the express written consent of A-dec, Inc., is strictly prohibited.

Regulatory Information and Warranty

For required regulatory information and the A-dec warranty, see the *Regulatory Information, Specifications, and Warranty* document (p/n 86.0221.00) available in the Resource Center at www.a-dec.com.

Product Service

Product service is available through your local authorized A-dec dealer. For service information, or to locate an authorized dealer, contact A-dec at 1.800.547.1883 in the USA and Canada or 1.503.538.7478 worldwide, or visit www.a-dec.com.

Product Models and Versions Covered in This Document

Model	Versions	Description
Performer 8000	B	Chair
Performer 8100	B	Delivery System
Performer 8200	B	Support Center
Performer 8500	B	Assistant's Instrumentation
Performer 8800	B	Monitor Mount

Content Map

Assistant's
Instrumentation.....21



Delivery System.....8

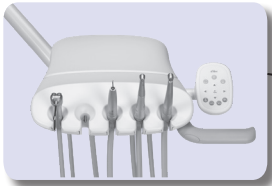

Footswitch.....4



Cuspidor..... 29



Chair.....2

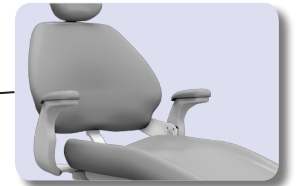

Touchpad Controls .. 13



Mechanical Adjustments.....	32
Cleaning and Maintenance.....	42
Specifications	48

Chair



Power and System Status

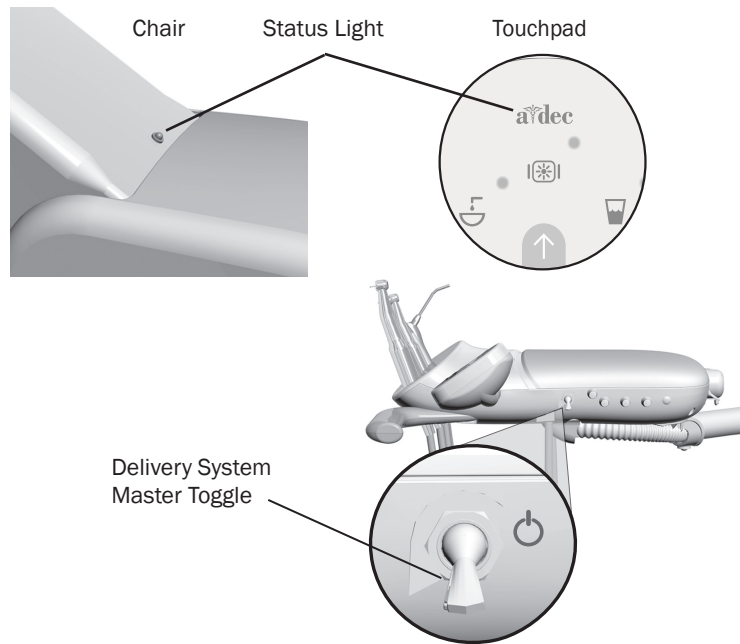

Power On/Off

To power on the Performer dental chair:

1. Verify that the chair is plugged into the mains supply.
2. Flip the master toggle up to turn on the chair. The master toggle is located on the delivery system.

The Performer dental chair does not have a power button.

When the A-dec logo on the touchpad or the status light on the chair lift arm illuminates, the system is on and ready for use. If the status light blinks, the stop switch has been activated. See “Chair Safety Features” below for more information.

When to Turn Off the Power

To save energy, use the master toggle to turn off the power at the end of the work day and during longer periods of non-use.

Chair Safety Features

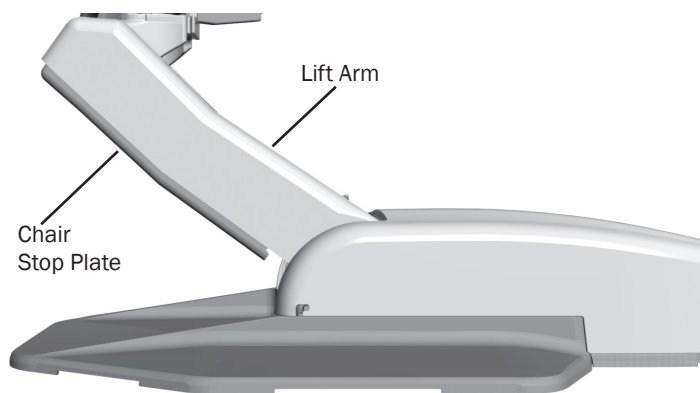

A-dec dental chairs and systems include several features designed to improve safety. Activated stop switches may halt the chair or prevent it from moving. To help ensure uninterrupted chair motion:

- remove any potential obstructions under the chair and attached modules
- avoid pressing the foot control disc or lever
- keep handpieces properly seated in their holders

If the Chair Stops Unexpectedly

Check the actions listed above to correct the condition. If the downward movement of the chair stopped because of an obstruction, use the touchpad or footswitch to raise the chair and remove the obstruction.

Footswitch Chair Controls

Manual Controls

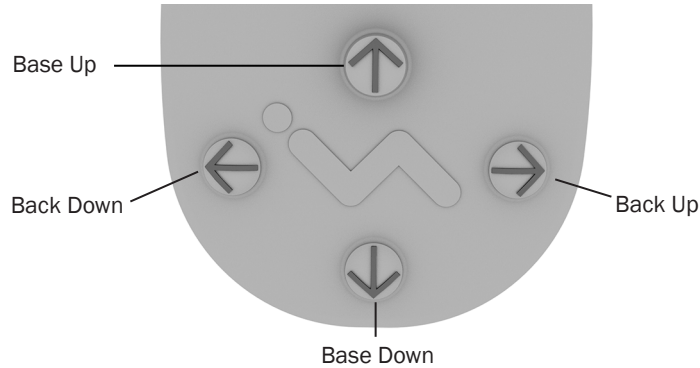

Programmable Controls

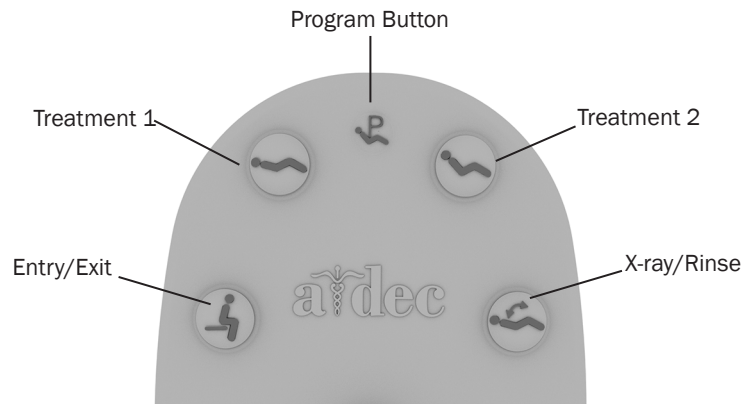

The A-dec touchpad and footswitch control chair movement in the same way. See “Touchpad Controls,” on page 13, for detailed information about your touchpad controls.

Manual Controls

Press and hold an arrow button until the chair is in the desired position. The horizontal arrows raise and lower the chair back. The vertical arrows raise and lower the chair base.

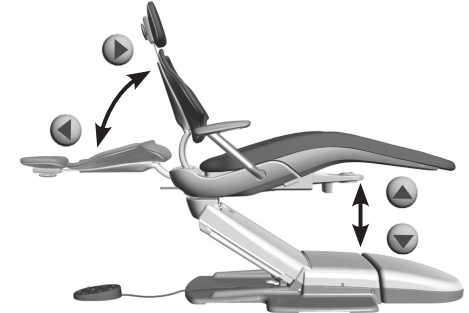

Programmable Controls

Press and release a programmable button to move the chair to a preset position. These buttons are programmed at the factory as follows:

Icon	Position	Factory Setting
	Entry/Exit	Positions the chair for patient entry/exit.
	Treatment 1	Positions the chair base and back down.
	Treatment 2	Positions the chair base down and back up.
	X-ray/Rinse	Moves the chair to either x-ray or rinse position. Press again to move the chair to the previous position.

Footswitch Chair Controls *(continued)*

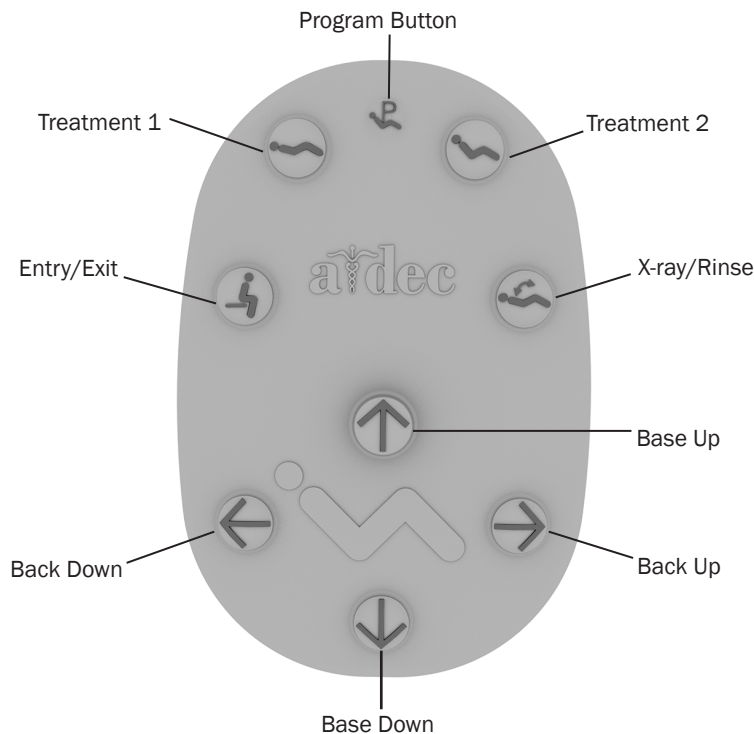



WARNING Ensure that the patient is positioned safely before using the manual or programmable chair controls. Never leave the patient unattended while the chair is in motion. Always take extra care with small children and patients with limited mobility.



To stop the chair at any point during programmed movement, push any chair positioning button on the footswitch or touchpad.

Reprogram Buttons 0, 1, and 2





To change the factory preset chair positions assigned to the entry/exit and treatment buttons (, , *):

1. Use the manual controls to position the chair as desired.
2. Press and release . One beep indicates that the programming mode is on.
2. Within five seconds, press the chair position button you wish to reprogram (for example, press ). Three beeps confirm that the new setting is programmed into memory.

Reprogram X-Ray/Rinse Button

The x-ray/rinse button () is preset to move the chair and patient into an upright position for x-rays or cuspidor access. A second press of  returns the chair to the previous position.

You can reprogram  to function in a similar way to the other programmable chair preset buttons. To change its function:

1. Press and hold  and  at the same time for three seconds.
 - One beep indicates  is set as another programmable chair preset button.
 - Three beeps confirm that  is configured as the x-ray/rinse factory preset (which toggles between the x-ray/rinse and the previous chair position).
2. If you reprogram  as another programmable button and want to assign a different chair position, follow the steps outlined in “Reprogram Entry/Exit, Treatment 1 and 2* Buttons” above.

Chair Back and Base Down Speed Adjustment

The chair back and base down speed can be adjusted. Contact your authorized A-dec dealer to reduce or increase the speed.

Headrest Positioning



The dual-articulating headrest includes several adjustment features that improve your access to the oral cavity and increase patient comfort.

Use the glide bar to accommodate a variety of patient heights. Simply pull up or push down on the headrest until it is in the desired position. The gliding headrest cushion provides additional height adjustment.



CAUTION If the glide bar has exceeded its maximum recommended working height, a warning line will be visible on the patient's side of the glide bar. Do not use the headrest in a position where this warning line is visible.

The locking knob allows you to easily adjust the headrest for a full range of positions. Release the headrest by turning the locking knob counterclockwise, then adjust the headrest for a proper fit. Lock the headrest in the desired position by turning the knob clockwise.

Headrest Position for Wheelchairs

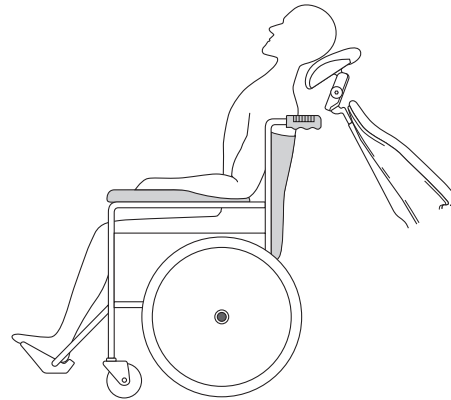

To position the headrest for wheelchairs:

1. Remove the headrest from the dental chair.
2. Rotate the headrest 180° and slide the glide bar into the backrest until it stops.
3. Position the backrest to its full upright position.
4. Position the wheelchair and the dental chair back to back.
5. Move the dental chair up or down, as needed, to adjust the headrest height.
6. Lock the wheelchair wheels.

Patient Positioning



To properly seat patients in the chair, ask the patient to sit as far back in the seat pocket as possible. This ensures the best alignment with the lumbar support and headrest.

For optimal comfort, patients should place their forearms on the armrests or keep their arms comfortably folded on their lap.



WARNING Do not allow patients to drop their arms behind the armrests or under the backrest during chair movement.

Delivery System

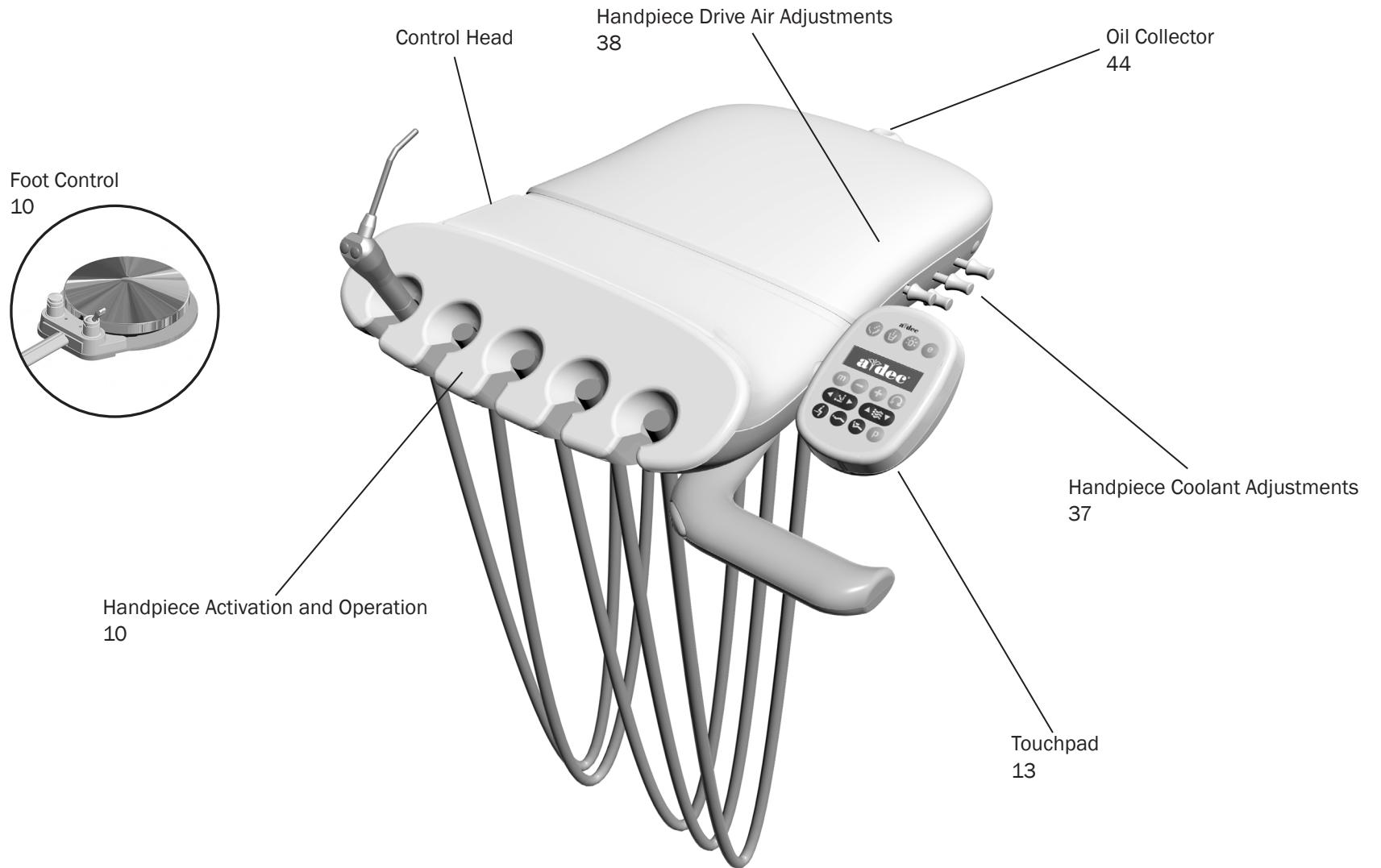

Autoclavable Syringe

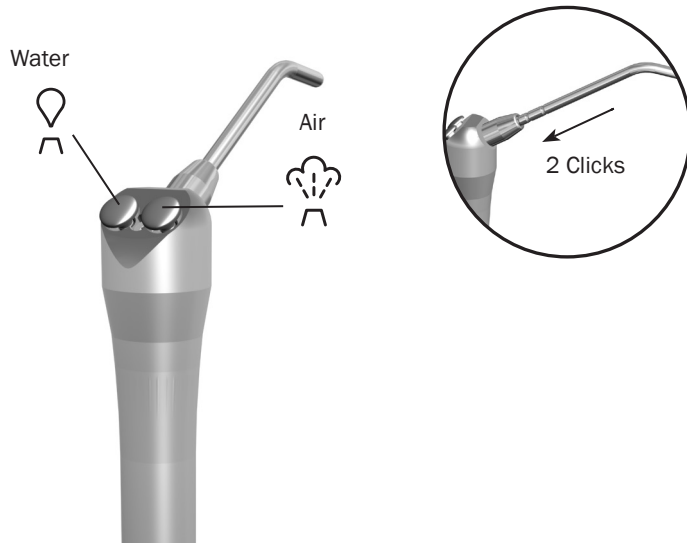

To install the A-dec syringe tip, push the tip in until you feel two clicks. Press both buttons simultaneously for the air/water spray.



IMPORTANT For detailed instructions on syringe usage, flow adjustment, and maintenance, see the *A-dec Syringes Instructions for Use* (p/n 85.0680.00).

Handpiece Activation and Operation

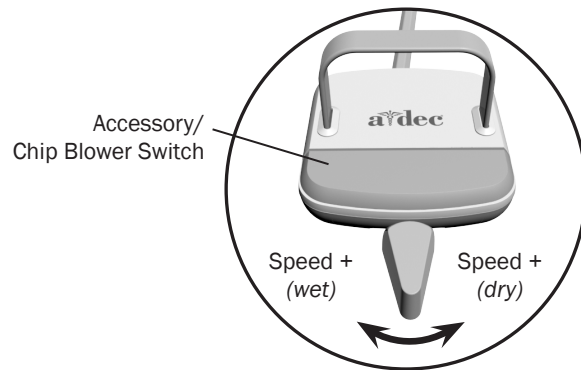
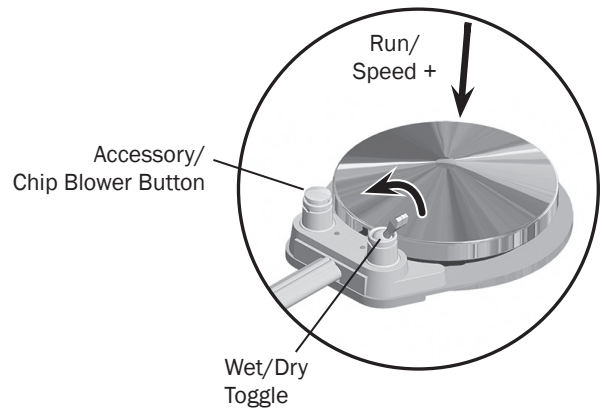

To activate a handpiece, lift it from the holder. Use the foot control to perform the desired handpiece operation.

Control	Operation	Procedure
Disc Foot Control	Run a handpiece.	Press on the disc. Push down to increase speed.
	Run a handpiece with or without water coolant.	Move the wet/dry toggle toward the blue dot for wet operation or away from the blue dot for dry operation. Then press on the disc.
	Run the optional accessory or chip blower.	Press the accessory/chip blower button.*
	Operate the intraoral camera.	Press on the disc to capture an image.*
Lever Foot Control	Run a handpiece with water coolant.	Move the lever to the left. Move farther to increase speed.
	Run a handpiece without water coolant.	Move the lever to the right. Move farther to increase speed.
	Run the optional accessory or chip blower.	Press the accessory/chip blower switch.*
	Operate the intraoral camera.	Move the lever to the left or right to capture an image.*

* Contact your authorized A-dec dealer for questions about the operation or configuration of your integrated A-dec accessories.

For handpiece coolant adjustments, see page 37.



NOTE The lever foot control function can be reversed by a technician (change left direction to dry, right direction to wet). For more details, contact your authorized A-dec dealer.

Control Head Positioning

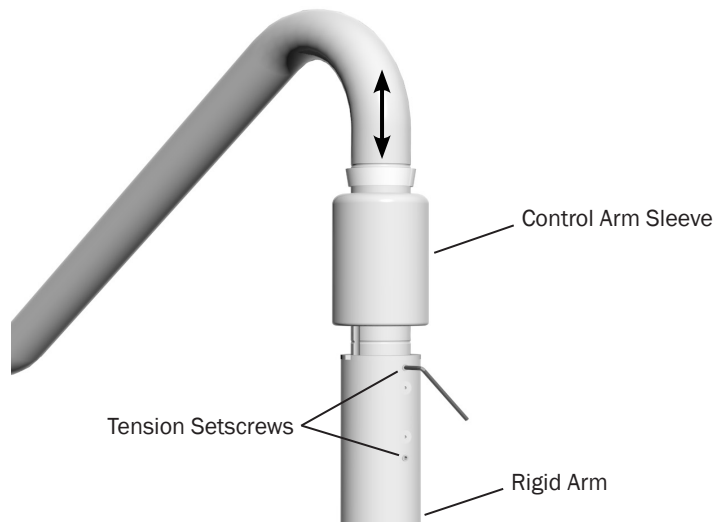
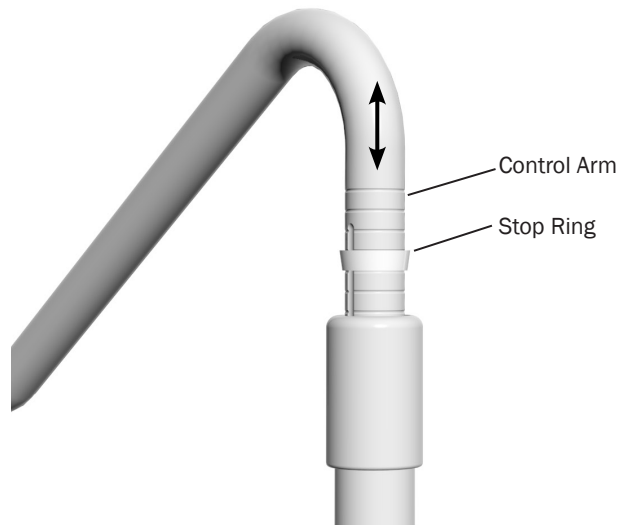

Performer Delivery System

To adjust the control head height:

1. Lift the control arm.



NOTE The height adjustment range for the control arm is 5" (127 mm).

2. Slide the stop ring to the desired height groove.
3. Lower the control arm until it stops.

If the control arm is difficult to rotate, or rotates too freely, you should adjust the tension setscrews on the rigid arm.

To adjust the control arm tension:

1. Lift the control arm.
2. Note the position of the stop ring and then lift it to the top height groove.
3. Lift the control arm sleeve to reveal the tension setscrews on the rigid arm.
4. Use a 3/32" hex key to loosen or tighten the two tension setscrews the same amount.
5. Lower the control arm sleeve and set the stop ring to its original position.
6. Lower the control arm.

Control Head Positioning *(continued)*



A-dec 332/333 Flexarm Brake

On systems with a counterbalanced flexarm, an integrated brake maintains the vertical position of the control head (with up to 8 lb [3.6 kg] of additional weight). The brake does not restrict side-to-side movement. To adjust the control head height:

1. Press and hold the button to disengage the brake while you position the control head.
2. Release the button to engage the brake.

Touchpad Controls



The A-dec touchpad and footswitch control chair movement in the same way. See your dental chair Instructions for Use for detailed information about your footswitch controls.

Basic Touchpad Functions

Your A-dec 300 system may include a standard or deluxe touchpad, or both. The standard touchpad operates the chair, cuspidor, and dental light functions. The deluxe touchpad adds functions for electric motors and other integrated clinical devices. Both touchpads provide manual and programmable controls.

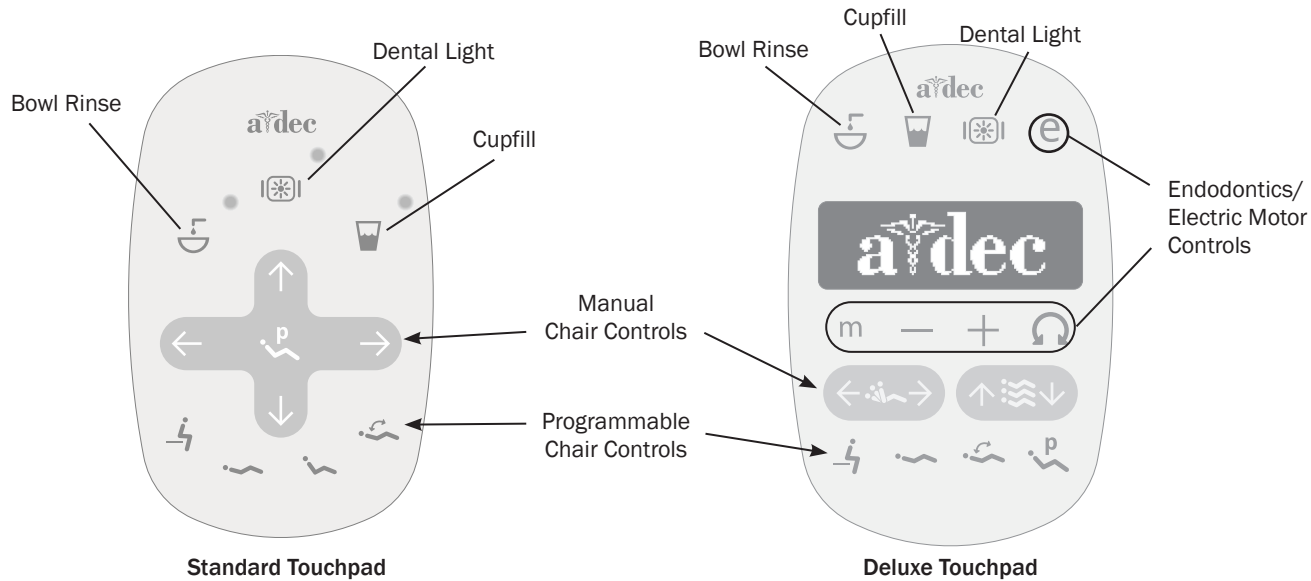

Touchpad Controls *(continued)*

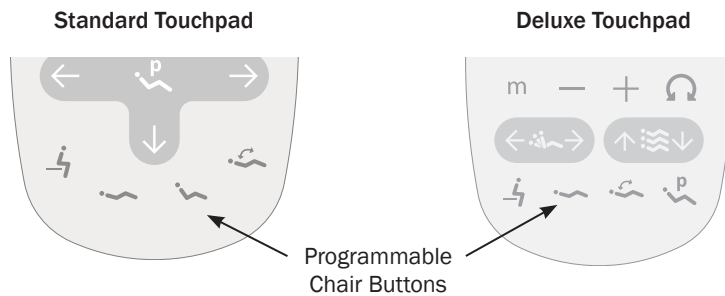
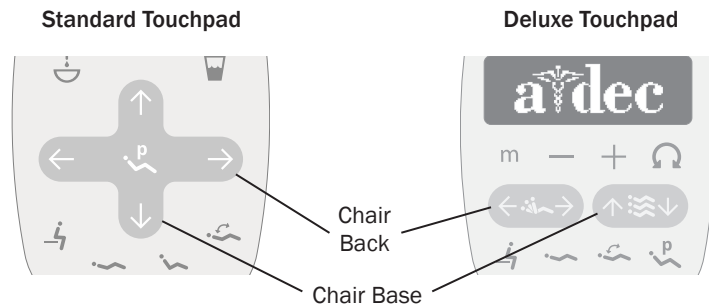

WARNING Ensure that the patient is positioned safely before using the manual or programmable chair controls. Never leave the patient unattended while the chair is in motion. Always take extra care with small children and patients with limited mobility.

To stop the chair at any point during preset movement, press any chair positioning button on the footswitch or touchpad.

Manual Chair Controls

Press and hold an arrow button until the chair is in the desired position. The horizontal arrows raise and lower the chair back. The vertical arrows raise and lower the chair base.

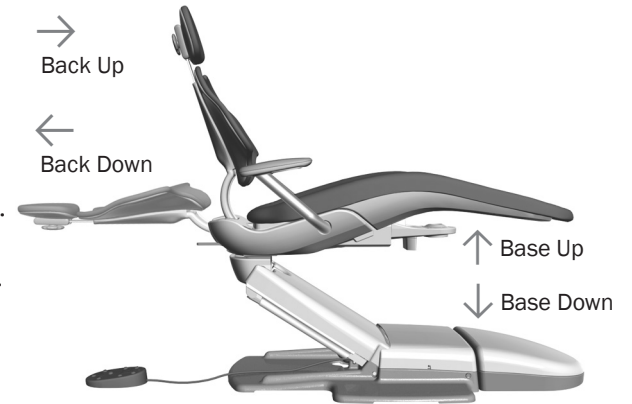

Programmable Chair Controls

Press and release a programmable button to move the chair to a preset position. These buttons are programmed at the factory as follows:

Icon	Position	Factory Setting
	Entry/Exit	Positions the chair for patient entry/exit.
	Treatment 1	Positions the chair base and back down.
	Treatment 2	Positions the chair base down and back partially up (standard touchpad only).
	X-ray/Rinse	Moves the chair to either x-ray or rinse position. Press again to move the chair to the previous position.

Note: Touchpad symbols are proprietary to A-dec Inc.

Touchpad Controls *(continued)*

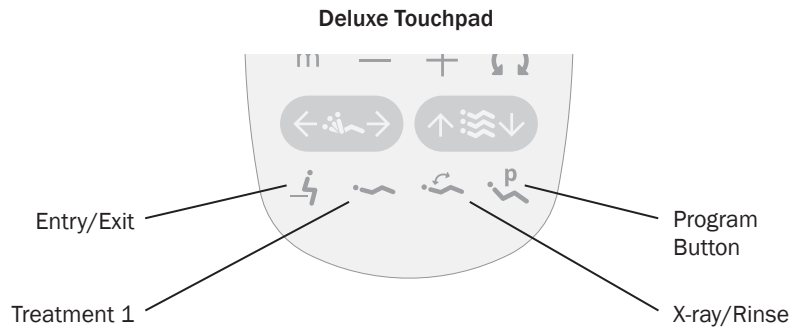
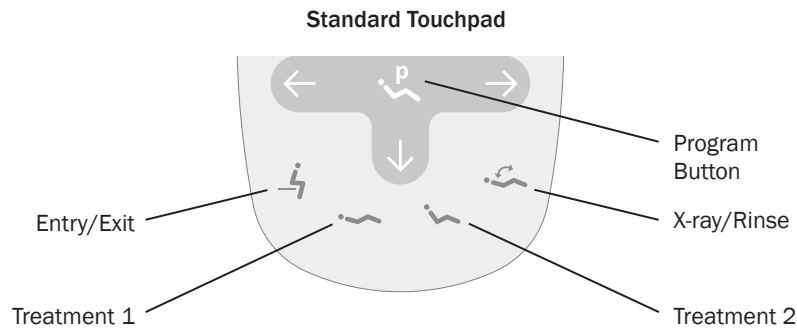

Reprogram Entry/Exit, Treatment 1 and 2* Buttons

To change the factory preset chair positions assigned to the entry/exit and treatment buttons (⚡, 🪑, 🪑*):

1. Use the manual controls to position the chair as desired.
2. Press and release **Ⓜ**. One beep indicates that the programming mode is on.
3. Within five seconds, press the chair position button you wish to reprogram (for example, press ⚡). Three beeps confirm that the new setting is programmed into memory.

** Note: The deluxe touchpad does not include a Treatment 2 button.*

Reprogram X-Ray/Rinse Button

The x-ray/rinse button (🪑) is preset to move the chair and patient into an upright position for x-rays or cuspidor access. A second press of 🪑 returns the chair to the previous position.

You can reprogram 🪑 to function in a similar way to the other programmable chair preset buttons. To change its function:

1. Press and hold **Ⓜ** and 🪑 at the same time for three seconds.
 - One beep indicates 🪑 is set as another programmable chair preset button.
 - Three beeps confirm that 🪑 is configured as the x-ray/rinse factory preset (which toggles between the x-ray/rinse and the previous chair position).
2. If you reprogram 🪑 as another programmable button and want to assign a different chair position, follow the steps outlined in “Reprogram Entry/Exit, Treatment 1 and 2* Buttons” above.

Touchpad Controls *(continued)*

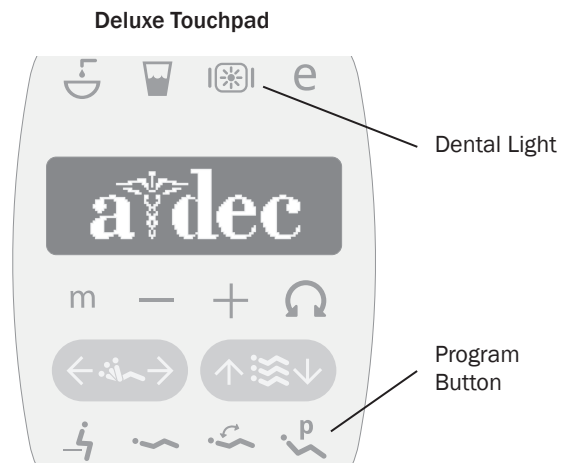
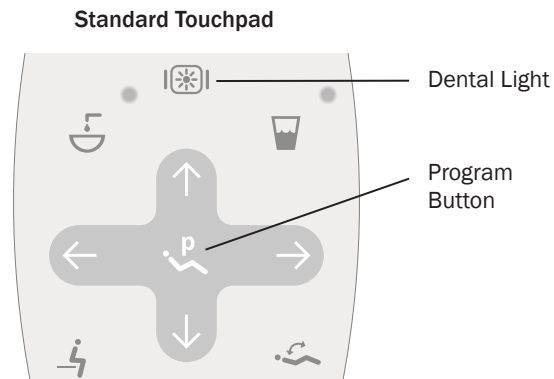

Dental Light Auto On/Off Feature

The auto on/off feature turns the A-dec light on once the chair reaches a preset treatment position.

When you press or , the dental light turns off and the chair moves to that preset position.

To disable the auto on/off feature, press and hold the program button and at the same time for three seconds until you hear one beep.

To enable the auto on/off feature, press and hold and at the same time for three seconds until you hear three beeps.



IMPORTANT For more information about dental light functions, see your dental light Instructions for Use.

Electric Handpiece Settings *(deluxe touchpad only)*

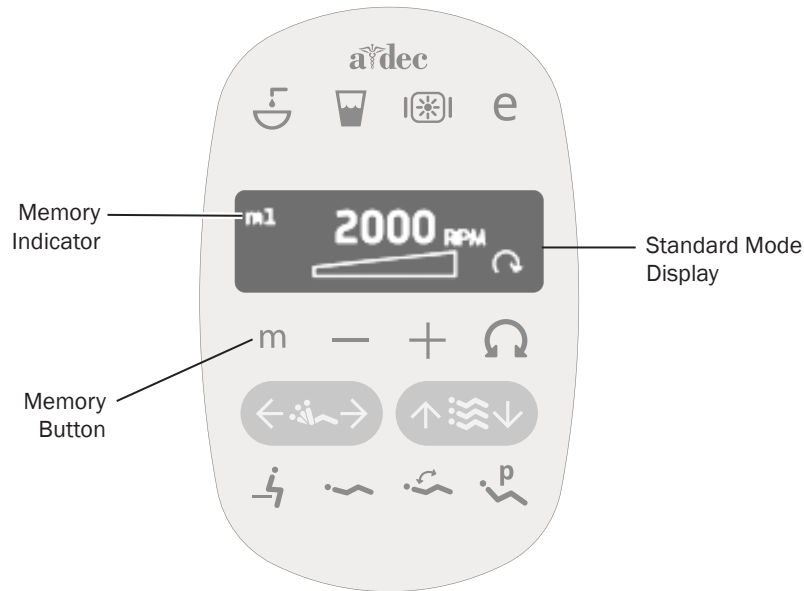

Standard Mode

To activate the electric motor, lift the handpiece from the holder. The touchpad screen displays the previous settings used for that handpiece position. Standard mode provides four factory preset speeds for electric motors:

Memory Setting	Factory Preset Speed
m1	2,000 rpm
m2	10,000 rpm
m3	20,000 rpm
m4	36,000 rpm

You can reprogram these memory settings with your own specific preset speeds. A total of eight customized settings per handpiece is possible (four in standard mode and four in endodontics mode).

To program the handpiece setting:

1. Press **-** or **+** until the rpm setting you want displays on the touchpad screen.
2. Press **P** to save it to memory. One beep sounds.
3. Press **m** to display the **m1** through **m4** memory settings. When the desired memory setting displays, press **P**. Three beeps confirm the setting.

Electric Handpiece Settings *(deluxe touchpad only) (continued)*

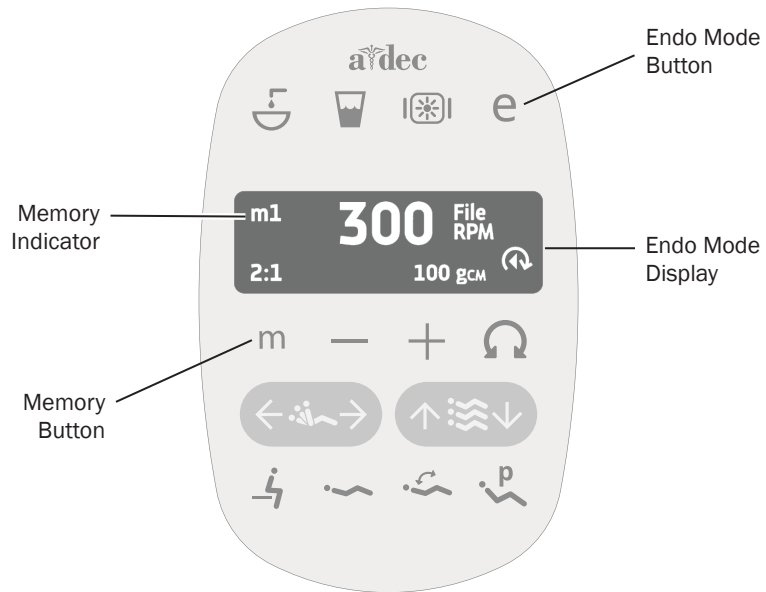

Endodontics (Endo) Mode

In addition to handpiece speed adjustments, the endo mode allows you to change a number of settings based on the specific file and desired handpiece behavior. Icons on the touchpad screen reflect the settings.



NOTE For more information regarding speed and torque limits for a specific file, consult the file manufacturer.

To program the handpiece setting:

1. Lift the handpiece from the holder.
2. If the touchpad screen does not display the endo mode, press **e**.
3. To change settings in endo mode, press **—** or **+**. A white reverse video box displays on the touchpad screen.
4. Use the chair positioning buttons to move from setting to setting on the touchpad screen.
5. Use **—** or **+** to change the setting as desired.
6. To set the speed limit, torque limit, or ratio into memory, press **p**. One beep sounds.
7. Press **m** to display the **m1** through **m4** memory settings. When the desired memory setting displays, press **p**. Three beeps confirm the setting.

Electric Handpiece Settings *(deluxe touchpad only) (continued)*

Endo Mode Touchpad Screen Icons

Icon	Setting	Description
	Speed	Setpoint for file speed limit. For more information, consult your file manufacturer.
	Torque	Setpoint for file torque limit. For more information, consult your file manufacturer.
	Torque Units	Toggles between newton centimeters (N·cm) and gram centimeters (g·cm). Adjusting this setting for one handpiece changes it for all handpiece settings. <i>Note: 1 N·cm = 102 g·cm.</i>
	Ratio	Sets the handpiece ratio. For more information, consult your handpiece manufacturer.
	Auto Modes	Adjusting this setting for one handpiece changes it for all handpiece settings. The auto mode indicator displays inside of the forward/reverse indicator.
	Auto Stop	<ul style="list-style-type: none"> When the file reaches the torque limit, the motor shuts off.
	Auto Reverse	<ul style="list-style-type: none"> When the file reaches the torque limit, the motor stops and reverses direction.
	Auto Forward	<ul style="list-style-type: none"> When the file reaches the torque limit, the motor stops, reverses 3 turns, then changes back to forward again <i>Note: If the file is stuck, the auto forward cycle repeats three times before the motor stops.</i>

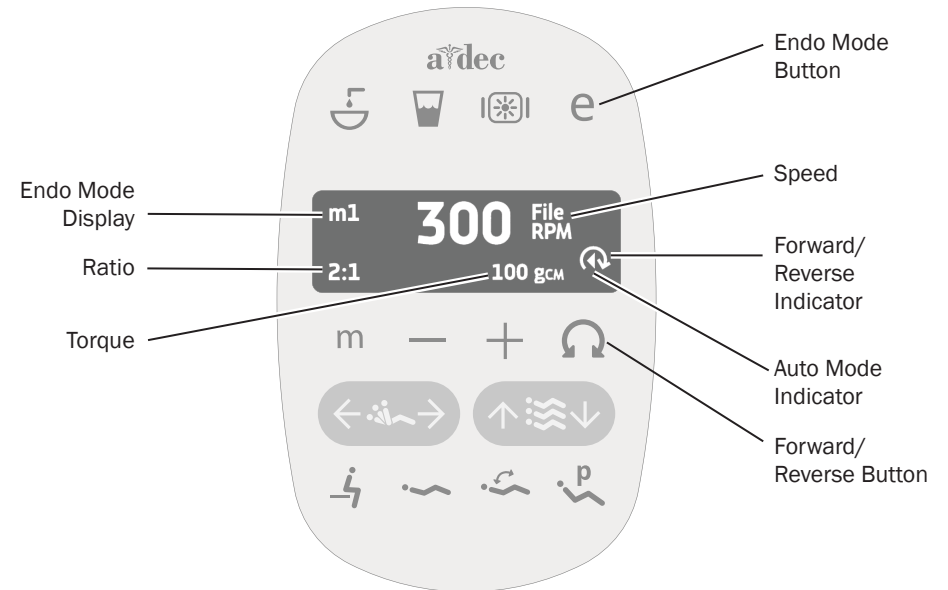

Forward/Reverse Button

The forward/reverse button changes the electric motor's direction. The system defaults to the forward position when you return the motor to the holder or turn off the system. In reverse mode, the screen icon flashes continuously.

Touchpad Help Messages

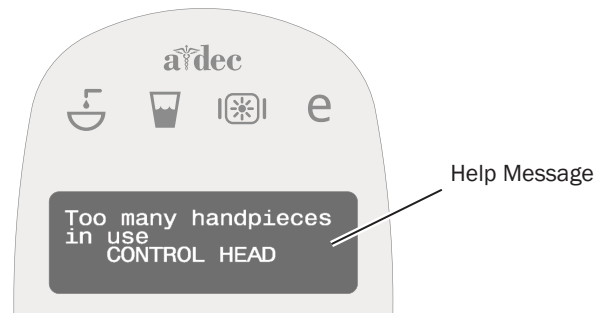

The deluxe touchpad screen displays help messages for disabled operations. When a help message appears, record the screen message and the function you were performing in case service is required. For complete details on help messages, see the *Regulatory Information, Specifications, and Warranty* document (p/n 86.0221.00) available in the Resource Center at www.a-dec.com.

Other Handpiece and Accessory Settings

See your authorized A-dec dealer to change any of these handpiece and accessory settings, if applicable:

- **Auto-Off Delay** - determines how long the handpiece light remains on if the foot control is released. The default setting is 5 seconds.
- **On When Selected** - specifies whether the handpiece light turns on or remains off when the handpiece is removed from the holder. The default setting is on.
- **On in Endo** - specifies whether the handpiece light turns on or off when the endo mode is selected. The default setting is off, which is recommended to reduce heat and extend bulb life.
- **Ultrasonic Colors** - for Acteon ultrasonic instruments, specifies whether color-coded tip categories are on or off. The default is on.
- **Voltage Adjustment** - allows for customized light output voltage for each handpiece position. The default setting is 3.2 VDC.

Assistant's Instrumentation

Instrument Holders

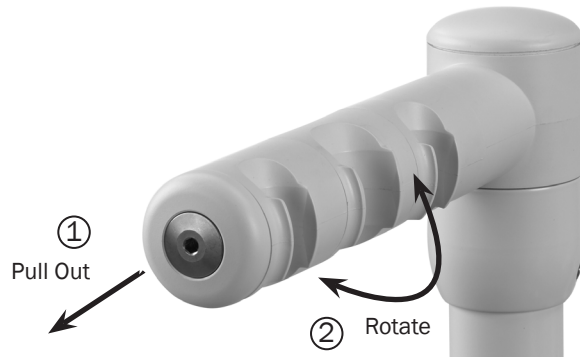

The instrument holders rotate independently to allow customized positioning for each instrument (with the auto-air holder option, the holders rotate only as a set). Pull the holder slightly away from the adjacent one, rotate to the desired position, and then release. To adjust as a complete set, pull from the holder closest to the touchpad.



CAUTION Twisting the holder without pulling it away from the adjacent one will damage the mechanism.

Air Vacuum System (AVS)

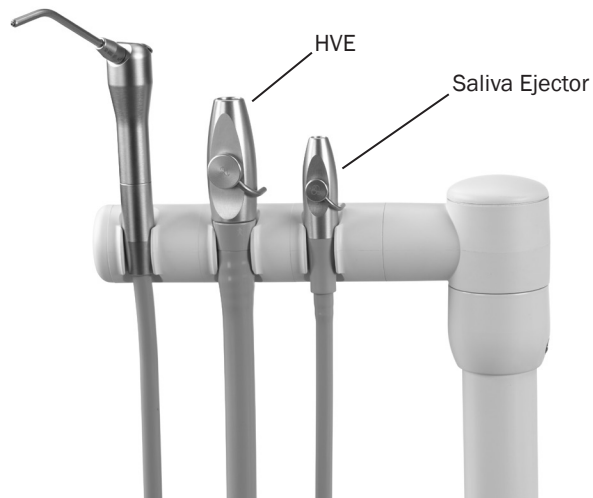

The optional Air Vacuum System (AVS) generates a vacuum using an air supply at 70 psi (483 kPa) minimum when a central vacuum system is not available. It also separates moisture and air that flows through the system and discharges them through a drain and air outlet.

On AVS-equipped systems, the assistant's instrumentation includes a feature called auto-air switching. Auto-air switching activates the air vacuum generator when the instruments are removed from the holder. Lift the instrument and open the valve for normal operation. Return the instrument to its holder to turn off the vacuum.

HVE and Saliva Ejector Right/Left Conversion

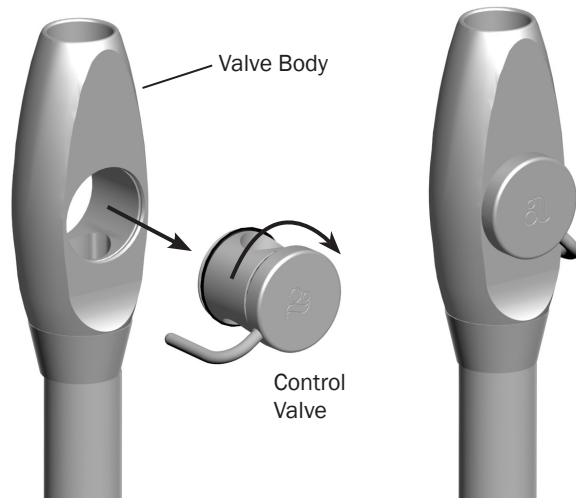

To convert the standard high-volume evacuator (HVE) and saliva ejector for left-handed operation, push the control valve out of the valve body, rotate the control valve 180°, and push it back into place.



NOTE Be sure to reinstall the valve on the same side of the valve body. Otherwise, the HVE or saliva ejector will not operate properly.

A-dec HVE/Saliva Ejector Valve Body Assembly Asepsis

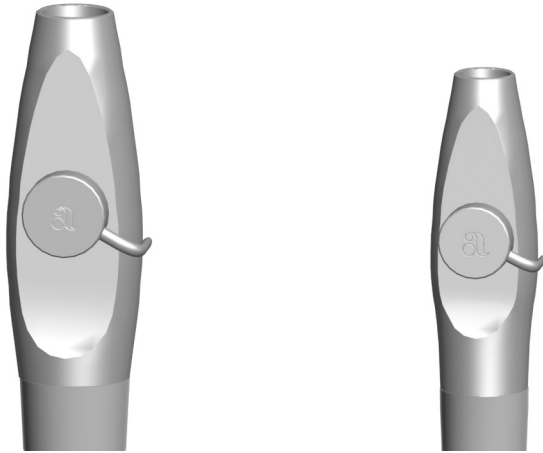

NOTE Vacuum lines should be flushed at the end of each day or more frequently according to your clinic's protocols.

If you use barriers to protect the main body of the HVE and saliva ejector, replace the barriers after each patient. Clean and disinfect these instruments at the end of each day or after each patient if the barriers have been compromised. If you do not use barriers, or if you perform oral surgery, always clean and disinfect these instruments after each patient.

Cleaning and Disinfection

To clean and disinfect the HVE and saliva ejector valve body assembly without disconnecting from the vacuum system:



CAUTION Clean the valve body assembly as soon as possible after treating each patient. Do not allow blood and debris to dry on instruments. If you cannot clean it immediately, keep the valve body assembly moist.



NOTE Use an intermediate-level EPA-registered hospital-grade disinfectant containing a tuberculocidal claim with one of the following compositions: high-dilution water-based phenolic formulation or quaternary ammonium compound with less than 25% isopropanol.



NOTE If using a spray solution, spray on a soft, low-lint wipe to apply solution to the valve body assembly.

1. Remove the vacuum tip from the HVE or saliva ejector valve body assembly. Discard disposable vacuum tips.

HVE/Saliva Ejector Valve Body Assembly Asepsis *(continued)*

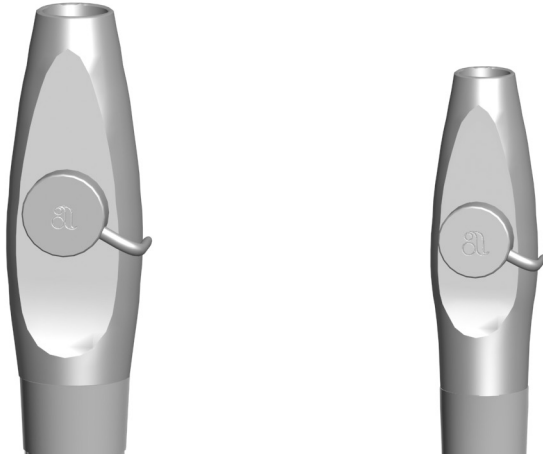

2. Clean the valve body assembly to remove visible soil using a disinfectant wipe or spray solution. Keep the valve body assembly wet according to the manufacturer's recommended contact time. Repeat, if necessary, until the valve body assembly is visibly clean.
3. Disinfect the valve body assembly using a new disinfectant wipe or spray solution. Keep the valve body assembly wet according to the manufacturer's recommended contact time.
4. Allow the valve body assembly to air dry.
5. Operate the HVE and the saliva ejector valves several times to verify that they rotate smoothly.



NOTE A-dec valve body assemblies are heat tolerant for sterilization. Users may sterilize at their discretion.

Routine Maintenance and Sterilization

To routinely maintain and sterilize the HVE and saliva ejector when disconnected from the vacuum system (frequency determined by the user):



CAUTION Clean the valve body assembly as soon as possible after treating each patient. Do not allow blood and debris to dry on instruments. If you cannot clean it immediately, keep the valve body assembly moist.

1. Remove the valve body assembly from the vacuum line by pulling it away from the tubing at the tailpiece.
2. Disassemble the valve body by pushing the control valve out of the valve body.
3. Clean soiled valve body components using a soft, low-lint wipe.

A-dec HVE/Saliva Ejector Valve Body Assembly Asepsis *(continued)*

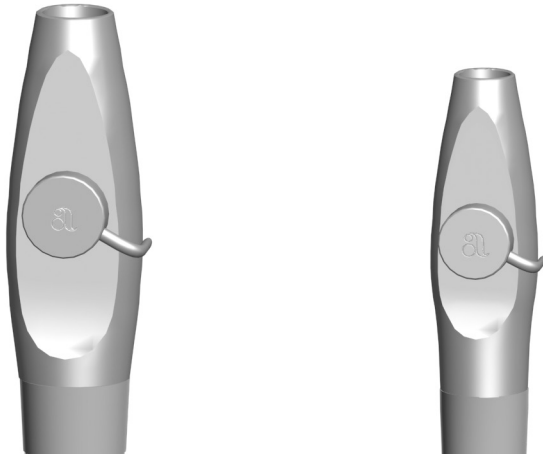

4. Prepare a warm (32-43°C [90-110°F]) detergent solution (neutral pH enzymatic detergent or alkaline non-enzymatic detergent), according to the manufacturer's recommended instructions.
5. Soak soiled valve body components in the prepared detergent solution for at least one minute.
6. Remove and inspect O-rings. Discard and replace, if damaged.
7. Use a soft, nylon-bristle brush, or equivalent, to scrub the:
 - Exposed surfaces of the valve body components and O-rings, while submerged, for a minimum of 30 seconds or until all visible soil has been removed.
 - Interior lumen of the valve body at least three times (in and out), clearing any visible soil from brush bristles.
8. Rinse the cleaned valve body components under flowing, warm (32-43°C [90-110°F]) potable water for a minimum of 30 seconds.
9. Allow valve body components to air dry.
10. Sterilize the valve body components according to the following:
 - Dynamic air-removal sterilizers: 4 minutes at 132-135°C (270-275°F)
 - Gravity-displacement sterilizers: 30 minutes at 121-123°C (250-254°F)
11. Allow the load to dry for 30 minutes before removing it from the sterilizer. Ensure the valve body components are completely dry before proceeding.



CAUTION Use only silicone lubricant when lubricating the black O-rings in A-dec instruments. Petroleum-based products will cause permanent damage to the O-rings.

12. Prior to use, lubricate O-rings with A-dec silicone lubricant, and reassemble the valve body assembly.

HVE/Saliva Ejector Valve Body Assembly Asepsis *(continued)*

13. Reinstall the valve body assembly on the tubing tailpiece.
14. Operate the HVE and the saliva ejector control valves several times to verify that they rotate smoothly.

HVE/Saliva Ejector Tips

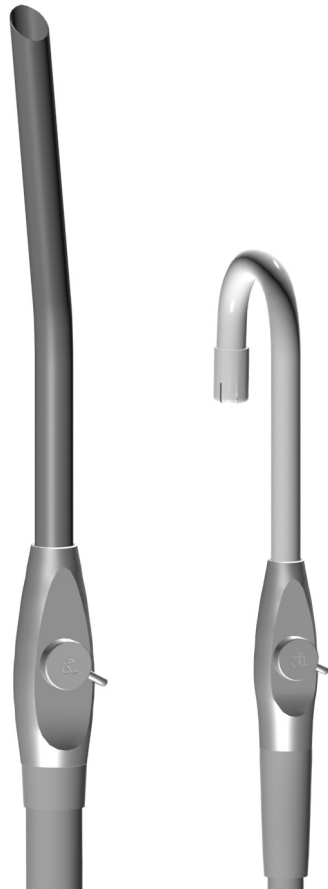

NOTE Select tips that are compatible with your HVE and saliva ejector openings. See “A-dec HVE/Saliva Ejector Tip Connections” on page 12 for specifications.

Disposable Tips



CAUTION Disposable HVE and saliva ejector tips are not sterilizable and should not be reused.



Replace disposable HVE and saliva ejector tips after each use.

Dürr HVE and Saliva Ejector Asepsis

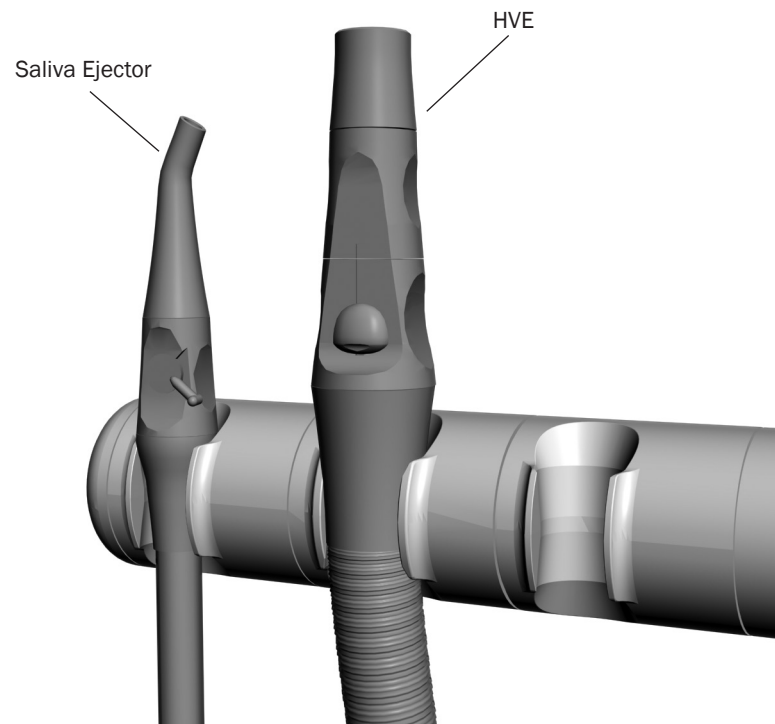

If you use barrier film to protect the main body of the Dürr HVE and saliva ejector, clean and sterilize these instruments weekly, or more frequently as needed. If you do not use barrier film, or if you perform oral surgery, clean and sterilize these instruments after each patient.



CAUTION Disposable HVE and saliva ejector tips are not sterilizable and should not be reused.



To clean and sterilize the Dürr HVE and saliva ejector:

1. Turn off the vacuum.
2. Remove the tip from the HVE or saliva ejector.
3. Remove the HVE or saliva ejector valve body by pulling it away from the tubing at the tailpiece.
4. Clean and rinse the valve body using a mild detergent, water, and a brush.
5. Allow the instruments to dry completely.
6. Heat sterilize the instruments using a steam autoclave for at least 6 minutes at a dwell temperature of 134 °C (273 °F).
7. Apply a light coat of petroleum-based lubricant on the red O-ring seal.



CAUTION Use only petroleum-based lubricant on red O-rings in Dürr instrumentation. Silicone lubricants can damage the material.

8. Reinstall the valve body on the tubing tailpiece.
9. Verify that the HVE and the saliva ejector operate and rotate smoothly.

Solids Collector

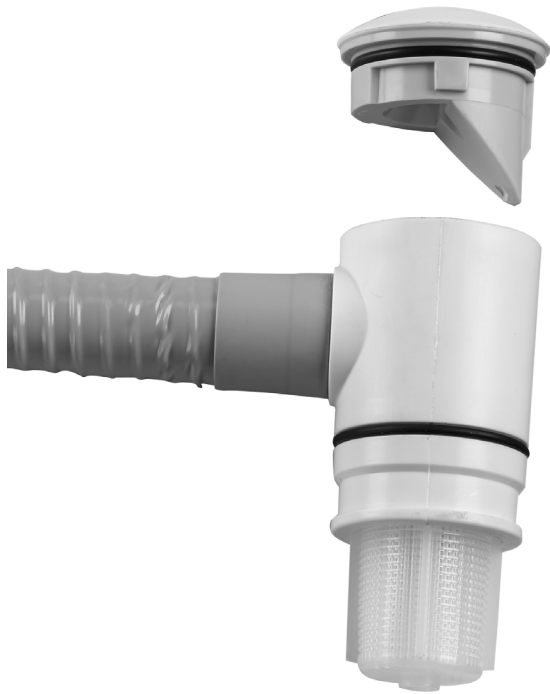

The solids collector helps prevent solids from entering the central vacuum system. To ensure proper suction from the central vacuum and maintain proper treatment room asepsis, discard and replace the solids collector screen at least twice a week.



WARNING Infectious waste may be present. Follow asepsis protocol to prevent cross contamination.



TIP To obtain replacement solids collector screens, contact your authorized A-dec dealer and reference Pinnacle p/n 5500.

To replace the solids collector screen:

1. Turn off the vacuum or open the HVE control valve.
2. Remove the solids collector cap.
3. Remove the solids collector screen.
4. Discard the screen according to your local regulations.

Cuspidor

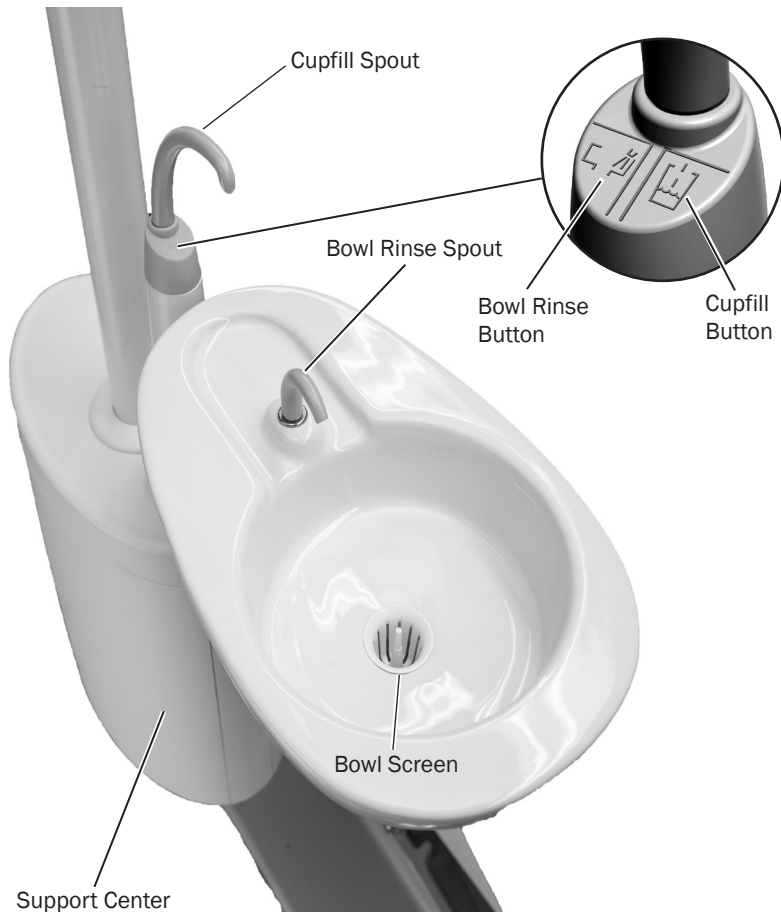

The cuspidor cupfill and bowl rinse functions can be controlled from the cuspidor or the touchpad.



Cuspidor Controls

Press and hold the cupfill button on the cuspidor for the desired amount of water. Release the button to stop the flow.

Press the bowl rinse button on the cuspidor once for a 15-second rinse. For continuous rinse, hold the button down. When you release the button, the water will continue to flow for 15 additional seconds.

Touchpad Controls

You can also use the buttons on the touchpad to operate and program bowl rinse and cupfill functions:

Button	Description and Action
	Cupfill Button: <ul style="list-style-type: none">• Press and release the cupfill button for a timed operation. The factory preset is a 2.5 second fill.• Press and hold the cupfill button for manual operation.
	Bowl Rinse Button: <ul style="list-style-type: none">• Press the bowl rinse button for a timed operation. The factory preset is a 30 second rinse.• Press and hold the bowl rinse button for manual operation.• Press the bowl rinse button twice in less than two seconds to activate the continuous operation mode. Press the button once to end the continuous operation mode.

Programming Cuspidor Buttons

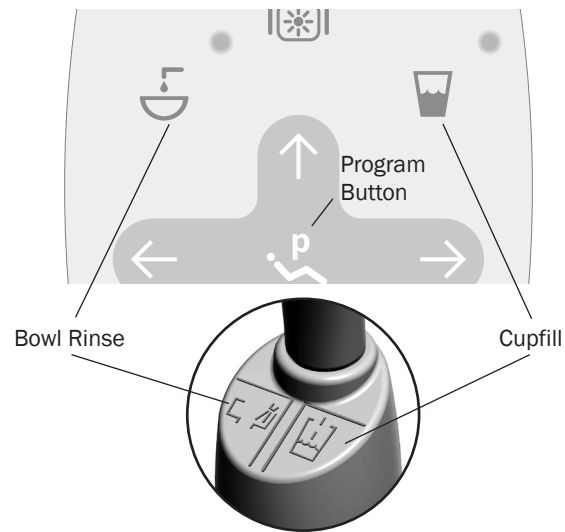

To reprogram the timed cupfill or bowl rinse functions:

1. Press  on the touchpad or press and hold both the cupfill and bowl rinse buttons on the cuspidor. Release them when you hear one beep.
2. Press and hold the cupfill or bowl rinse button for the desired time.
3. Release the button. Three beeps confirm that the program has changed.

Bowl Rinse Flow Adjustment

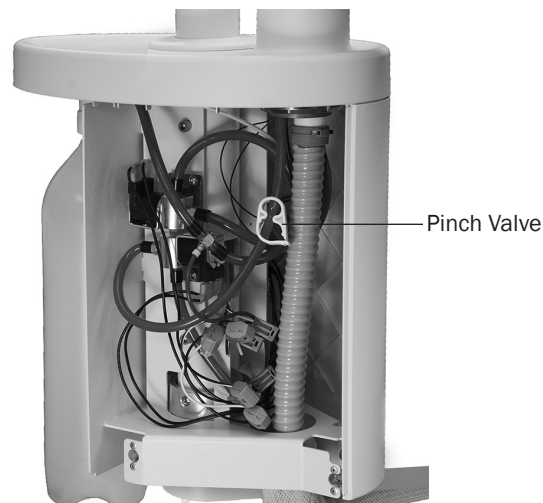

Adjustments to the cuspidor bowl rinse flow are made inside the support center. To make an adjustment:

1. Carefully pull the bottom edge of the cover out and remove the cover.
2. With the cuspidor bowl rinse on, tighten or loosen the pinch valve to adjust the flow.
3. For the best rinsing action, adjust the flow pattern by rotating the bowl rinse spout.

Dental Light

Touchpad Controls

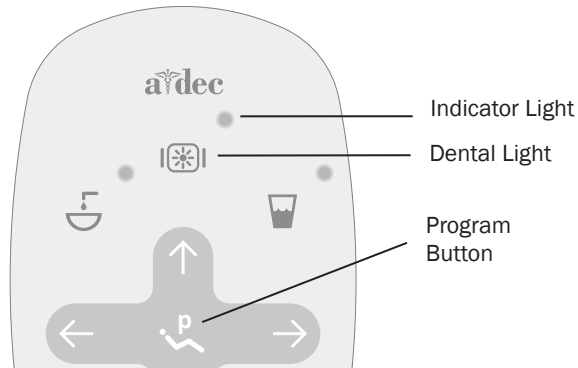

Standard Touchpad



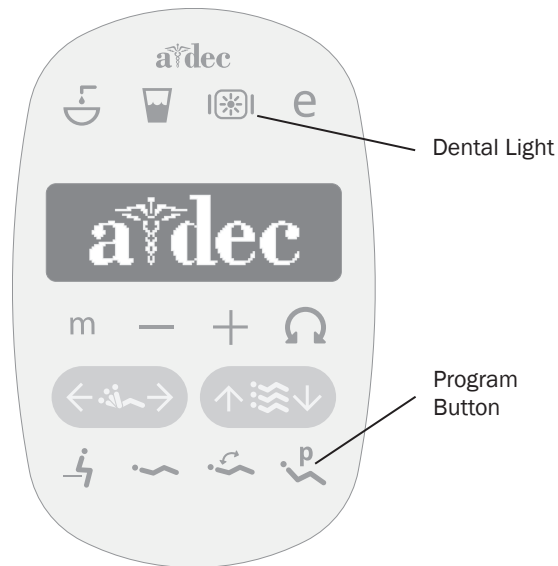



Deluxe Touchpad





Turn On/Turn Off the Dental Light and Change the Intensity

- To turn on the light, press .
- To change the light intensity mode, press . The indicator light flashes continuously in cure-safe and composite/low modes.
- To turn the light off, press and hold .

Set the Dental Light Auto On/Off Function

When you press  (also  on the standard touchpad), the dental light automatically turns on once chair motion stops. The light turns off when you press  or .

To disable or enable this function, press and hold  and  at the same time.

- One beep indicates the function is off.
- Three beeps indicate the dental light auto on/off function is on.



IMPORTANT For more details on dental light operation, see your dental light Instructions for Use.

Mechanical Adjustments

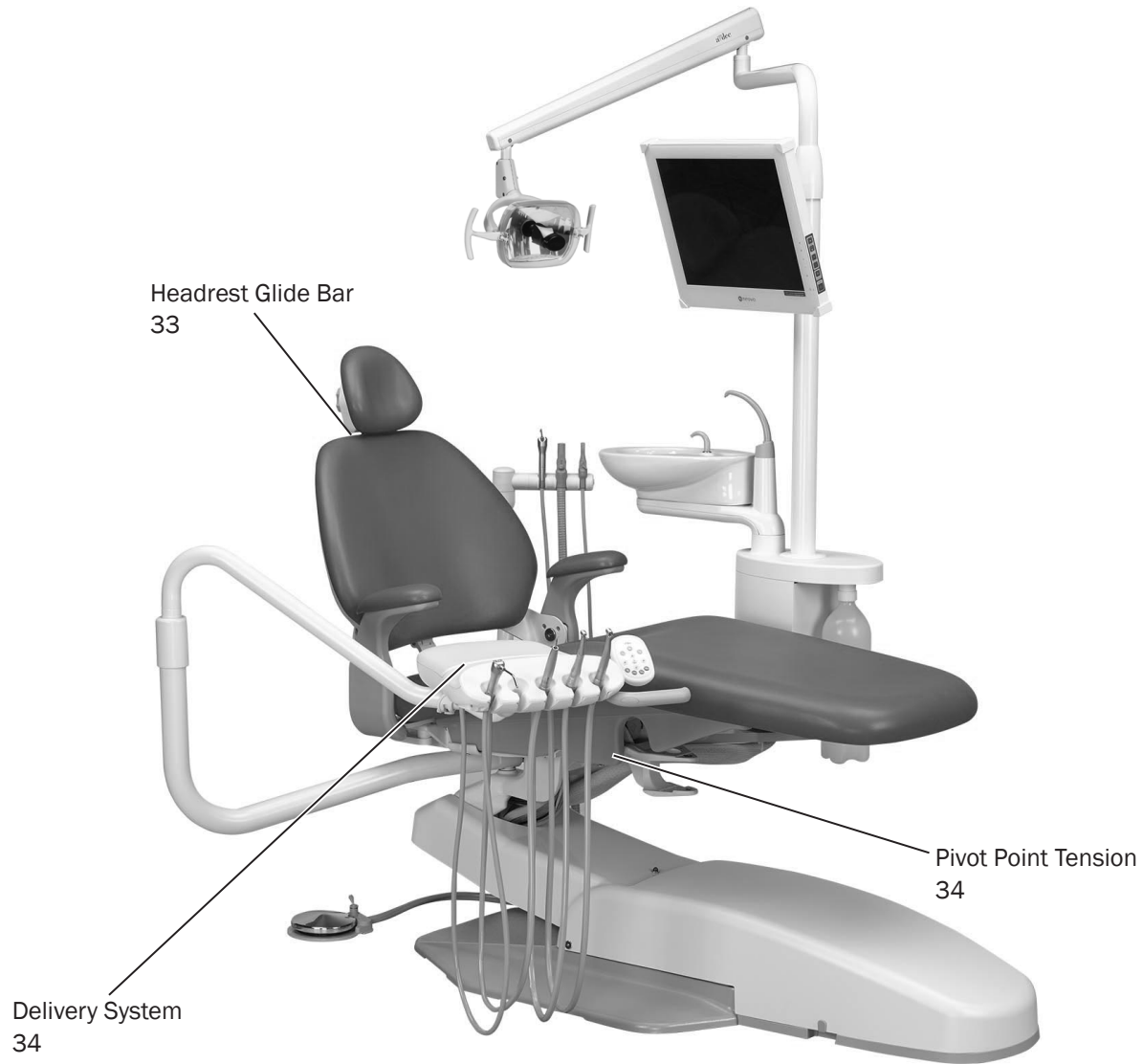

Chair Adjustments

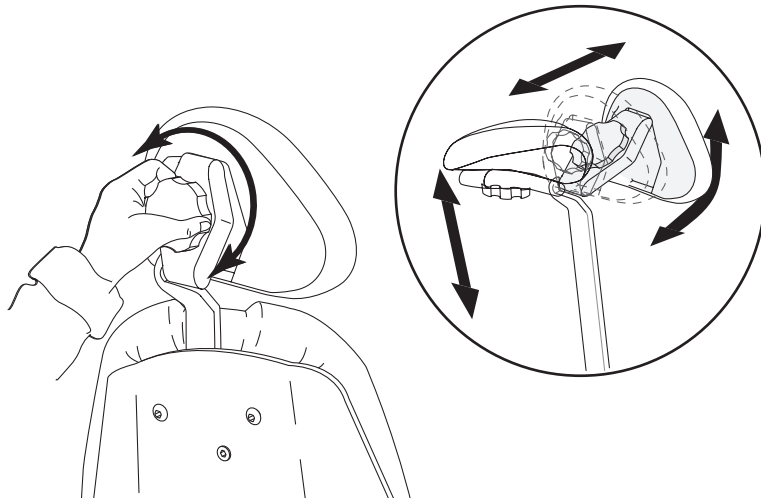

Headrest Positioning

The headrest includes several adjustment features that improve your access to the oral cavity and increase patient comfort.

Use the glide bar to accommodate a variety of patient heights. Simply pull up or push down on the headrest until it is in the desired position. The gliding headrest cushion provides additional height adjustment.



CAUTION If the glide bar has exceeded its maximum recommended working height, a warning line will be visible on the patient's side of the glide bar. Do not use the headrest in a position where this warning line is visible.

The locking knob allows you to easily adjust the headrest for a full range of positions. Release the headrest by turning the locking knob counterclockwise, then adjust the headrest for a proper fit. Lock the headrest in the desired position by turning the knob clockwise.

Headrest Glide Bar Tension Adjustment

If the headrest drifts downward, or if it is difficult to move up or down, the glide bar tension needs adjustment.

To adjust the tension, use a 1/8" hex key. Turn the tension adjustment screw clockwise to increase friction or counterclockwise to decrease friction.

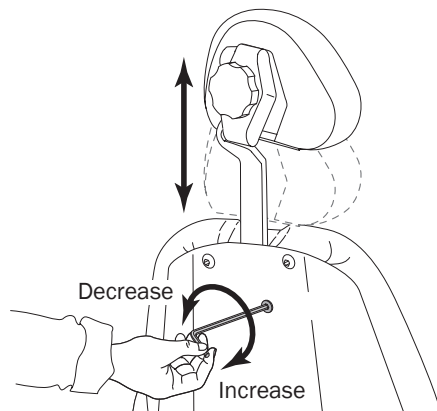

Delivery System Adjustments



Pivot Point Tension Adjustments

If the delivery system drifts, you can adjust the tension on the delivery system rigid arm.

Adjust the Back-Mount Delivery System or Dental Light Tension

1. Use a 5/32" hex key to remove the four screws that secure the seat upholstery to the chair casting and remove the upholstery.
2. Lower the seat back all the way down. This provides access to the back-mount tension adjustment screw.

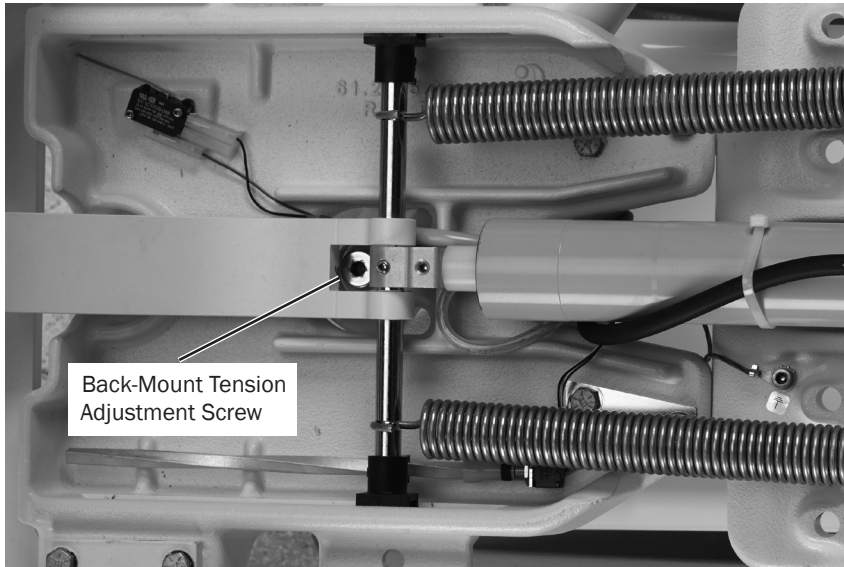

Adjust the Back-Mount Delivery System or Dental Light Tension
(continued)

1. Use a 1/4" hex key to adjust the tension of the screw. Adjust the screw until the arm rotates easily but does not drift.
2. Reinstall the seat upholstery and secure it with the four screws removed earlier.

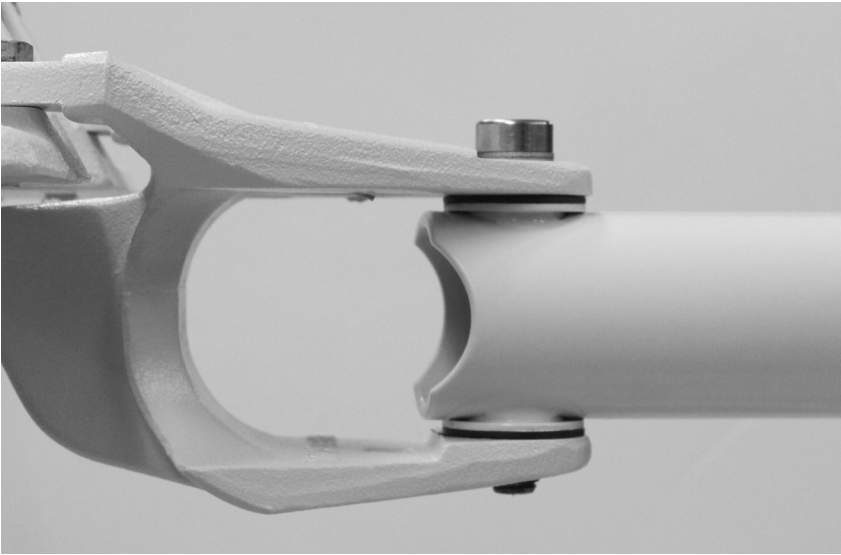

Adjust the Front-Mount Delivery System or Dental Light Tension

The front-mount tension adjustment is accessed below the seat upholstery at the front of the chair.

1. Use a 1/4" hex key to adjust the tension of the screw. Adjust the screw until the arm rotates easily but does not drift.



CAUTION When performing this procedure, do not attempt to completely shut off the water or air flow. The adjustment knobs are not designed to completely shut off flow and can damage the control block if you apply too much force.

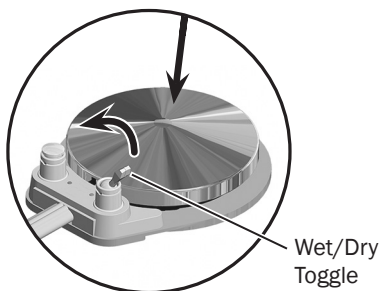
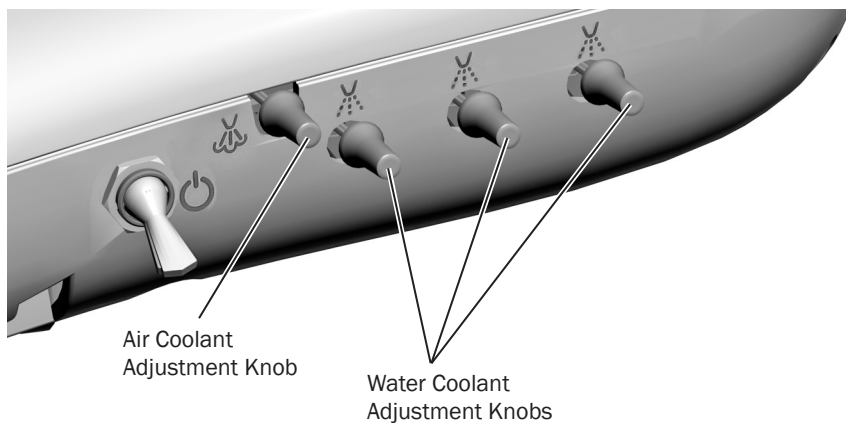

Disc Foot Control

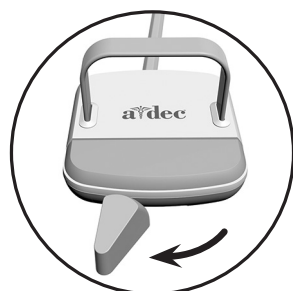

Lever Foot Control

Handpiece Coolant Adjustments

The air coolant knob on your delivery system simultaneously adjusts air flow to all handpiece positions. Each water coolant knob adjusts water flow to a single position. Use the following process to adjust for the desired handpiece coolant atomization:

1. Insert a bur into each handpiece you are adjusting.
2. Turn the air coolant adjustment knob clockwise until coolant flow stops.
3. Lift the handpiece from the holder, or pull the whip forward, and do one of the following:
4. On a disc foot control: flip the wet/dry toggle to water (toward the blue dot) and press the disc all the way down.
5. On a lever foot control: move the lever all the way to the left.
6. Locate the water coolant adjustment knob for the handpiece position you are adjusting and turn it clockwise until coolant flow stops.
7. Slowly turn the water coolant adjustment knob counterclockwise until water droplets are expelled from every water port on the handpiece head. Return the handpiece to the holder.
8. Repeat steps 3 through 5 for each handpiece.
9. To set the air coolant for the system, lift a handpiece from the holder or pull the whip forward.
10. Turn the air coolant adjustment knob counterclockwise until you achieve the desired atomization at the cutting surface of the bur.



CAUTION Do not continue turning the air coolant adjustment knob counterclockwise after the air coolant stops increasing. The stem may come out of the control block.

11. If you require more water coolant, increase the water output in step 5 as needed.

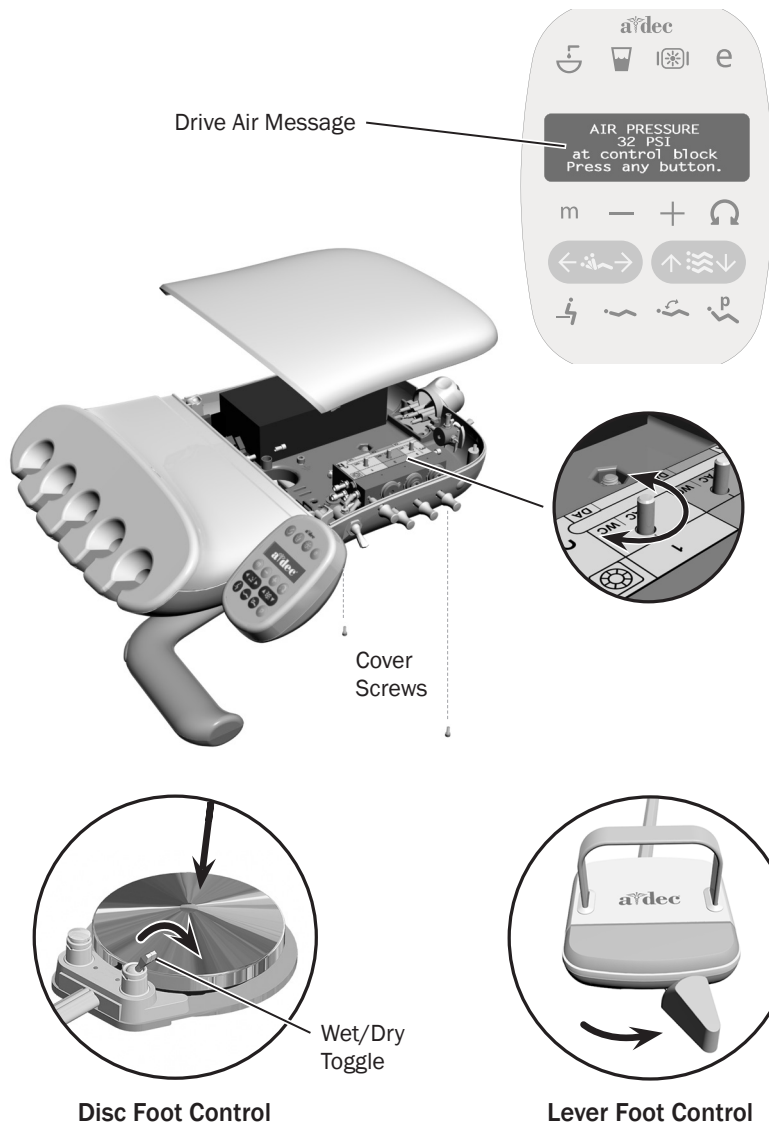

Handpiece Drive Air Adjustments

You can check drive air pressure on the deluxe touchpad screen by pressing **+** and **-** at the same time. For systems with a standard touchpad, and for the most accurate drive air measurement, use a handpiece pressure gauge (A-dec p/n 50.0271.00) attached to the handpiece tubing.

To adjust the drive air pressure for each handpiece:

1. Remove the control head cover screws. Remove the cover and locate the drive air pressure controls inside.
2. Lift the handpiece from the holder or pull the whip forward.
3. Do one of the following:
 4. On a disc foot control: flip the wet/dry toggle to dry, and press the disc all the way down.
 5. On a lever foot control: move the lever all the way to the right.
6. With the handpiece running, check the deluxe touchpad readout or handpiece pressure gauge.
7. Adjust the handpiece drive air pressure to meet the manufacturer's specifications. Turn the control stem clockwise to decrease flow and counterclockwise to increase flow.



CAUTION See your handpiece documentation for the drive air pressure specification. Exceeding manufacturer's recommendations increases the risk of damage and may significantly decrease the life of your handpiece components.

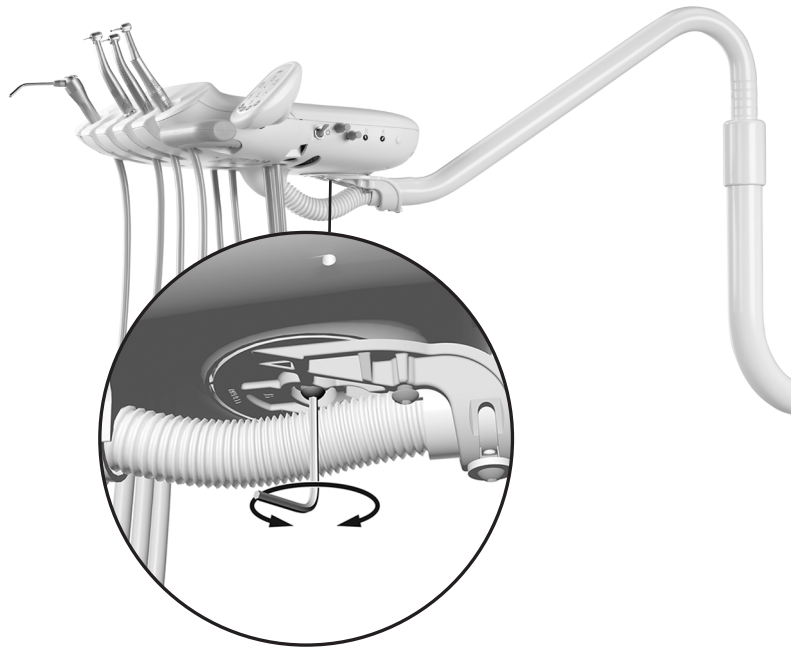

Rotational Adjustments

Control Head

If the control head is too loose or difficult to rotate, use a 5/32" hex key to adjust the tension screw under the control head.

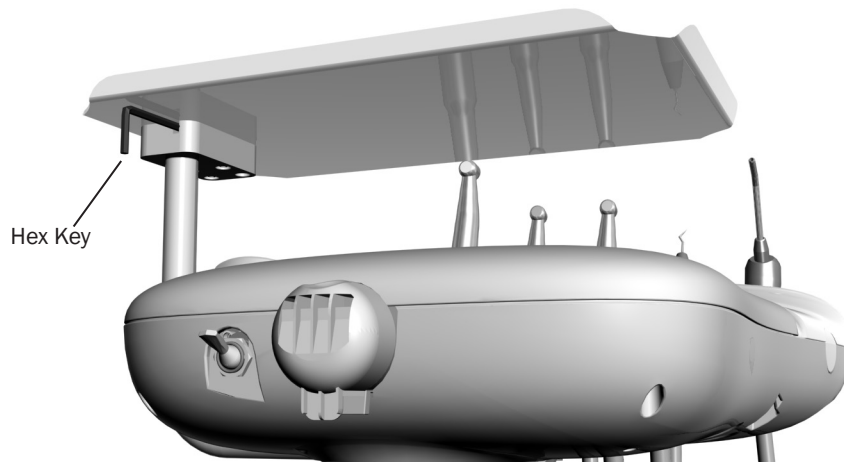

Tray Holder

If the tray holder rotation is too tight or too loose, use a 9/64" hex key to adjust the tension:

1. Insert the hex key through the mounting bracket. If necessary, rotate the holder or arm until the key slides completely into the mounting bracket.
2. While holding the bracket stationary, turn the tray holder clockwise to increase the tension or counterclockwise to reduce the tension.

Vertical Adjustments

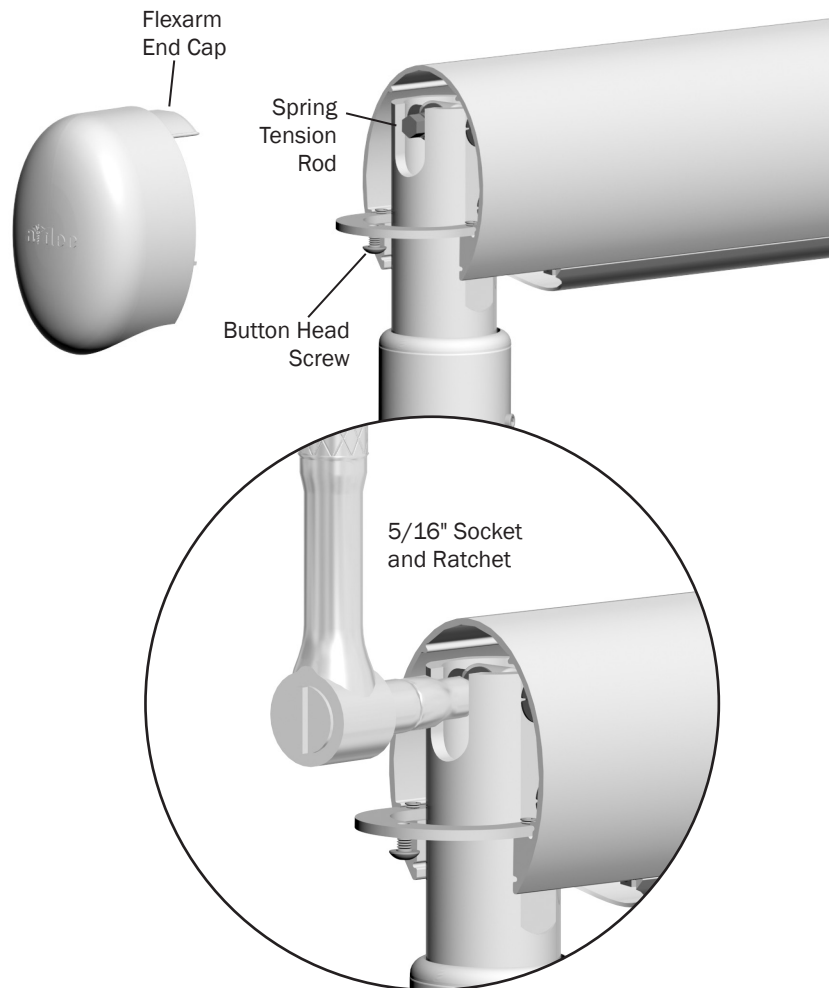

On systems that have a counterbalanced flexarm: If the control head falls or rises rapidly when you flip the master toggle to the off position, complete these steps to adjust the flexarm spring tension:

1. Flip the master toggle to the on position.
2. Load the control head for normal use, attaching handpieces and placing a tray on the tray holder.
3. Position the control head so the flexarm is level.
4. Use a 1/8" hex key to loosen the button head screw that secures the end cap farthest from the control head, then pull the cap straight out.
5. Flip the master toggle to the off position.
6. Use a 5/16" socket and ratchet to adjust the flexarm spring tension rod until the control head rises gradually when you flip the Master toggle to the off position.
 - If the control head rises rapidly, turn the rod counterclockwise.
 - If the control head falls, turn the rod clockwise.

Dental Light Adjustments



Refer to the *Instructions for Use* that shipped with your light for detailed adjustment instructions.

Cleaning and Maintenance

Barrier Protection

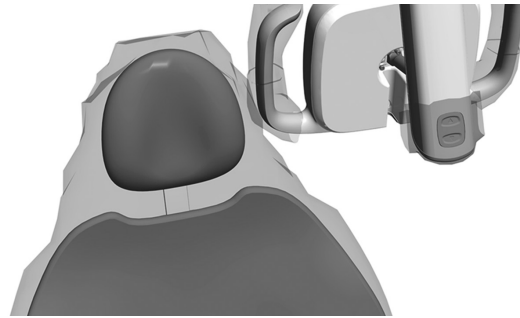

A-dec recommends barrier protection for all applicable touch and transfer surfaces. Touch surfaces are areas that come into contact with hands and become potential cross-contamination points during dental procedures. Transfer surfaces are areas that come into contact with instruments and other inanimate objects.

In the USA, barriers must be produced under the Current Good Manufacturing Practice (CGMP) as specified by the U.S. Food and Drug Administration (USFDA). For regions outside the USA, refer to the medical device regulations specific to your location.



NOTE For proper use and disposal of barriers, see the instructions provided by the barrier manufacturer.



IMPORTANT For recommendations on cleaning and chemical disinfection of touch and transfer surfaces (where barrier protection is not applicable or when barriers are compromised), please see the *A-dec Equipment Asepsis Guide* (p/n 85.0696.00).

Waterline Maintenance



Self-Contained Water Bottle



A-dec recommends that you perform a shock treatment on the dental unit waterlines before you use the system for the first time.

For on-going waterline maintenance, A-dec recommends a three-part protocol: continuous use of A-dec ICX® waterline treatment tablets, regular dental unit water quality monitoring, and shock treatment.



IMPORTANT For complete details on how to maintain good water quality in your system, see the instructions for use provided with ICX and your self-contained water bottle:

A-dec ICX p/n 86.0613.00

A-dec Self-Contained Water System p/n 86.0609.00

Waterline Maintenance Guide p/n 85.0983.00

Upholstery



CAUTION Do not use household bleach (sodium hypochlorite) or other products containing chlorine, isopropyl alcohol (greater than 25 percent by volume), or hydrogen peroxide to clean or disinfect the upholstery. It can cause rapid deterioration and damage the product.

To preserve the quality of your A-dec upholstery, use barrier covers instead of relying on chemicals. Barriers significantly extend the life of the upholstery and will help to preserve its luxurious look and soft feel. To clean the upholstery, use a solution of mild detergent and water. Use surface disinfectants only when the barriers have been compromised or there is visible spatter on the upholstery. For more information, see the *Upholstery Maintenance Guide* (p/n 86.0501.00), which is available in the Document Library at www.a-dec.com.

Self Contained Water System



The self-contained water system supplies water to handpieces, syringes, and cuspidor cupfill. For complete instructions on water usage in your Performer system, refer to the *A-dec Self-Contained Water System Instructions For Use* (p/n 86.0609.00) included with your equipment.

Cleaning the Handpiece Tubing

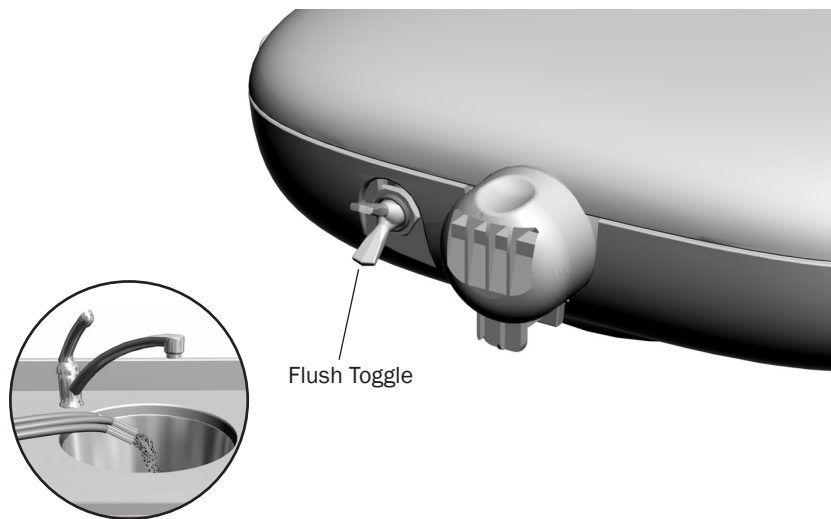

Use the flush toggle to move a high volume of water through the handpiece tubing. To flush the tubing after each patient:

1. Disconnect the handpieces.
2. Hold all of the handpiece tubing that uses water coolant over a sink, cuspidor bowl, or basin.
3. Hold the flush toggle down for 20–30 seconds.



NOTE Discharge all tubing air and water lines for 20–30 seconds after each patient.



IMPORTANT For recommendations on cleaning and chemical disinfection of touch and transfer surfaces (where barrier protection is not applicable or when barriers are compromised), please see the *A-dec Equipment Asepsis Guide* (p/n 85.0696.00).

Servicing the Oil Collector

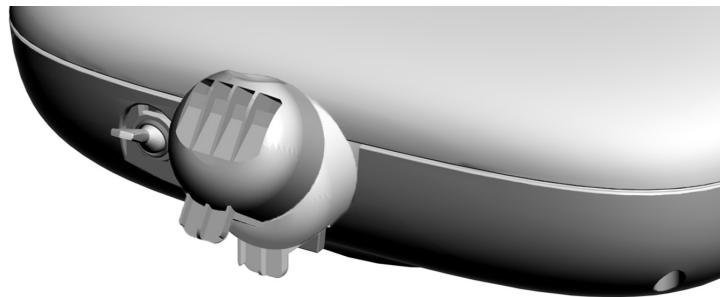

Service the oil collector on the delivery system once a week for normal usage and more often for heavier use. To service:

1. Unsnap the oil collector cover from the control head and discard the old gauze. Do not remove the foam muffler.
2. Fold a new gauze pad (2" x 2" [51 mm x 51 mm]) into quarters and place it inside the cover.
3. Snap the oil collector cover closed.

Cleaning the Cuspidor Bowl



The contoured spouts and smooth bowl of the cuspidor provide for quick and easy cleaning. Remember to empty and clean the bowl screen every time you clean the cuspidor.



CAUTION Do not remove the spouts when cleaning the cuspidor. This will help prevent cleaning solutions from damaging the equipment and contaminating the cupfill water.



CAUTION Do not empty the solids collector or bowl screens into your cuspidor. Doing so could plug the cuspidor drain. After cleaning, always install the bowl screen in the cuspidor bowl drain to prevent debris from plugging the drain.

Gravity Drain Cleaning

At the end of each day, flush the cuspidor to remove debris from the flexible drain tubing. If the cuspidor is not flushed regularly, debris may build up and impair draining. To flush the cuspidor, run the bowl rinse for about 60 seconds.

Maintenance Parts



Bowl Screen

For replacement cuspidor bowl screens, order p/n 75.0035.03.

Dental Light Shield Maintenance

Refer to the *Instructions for Use* that came with your dental light for information on dental light shield maintenance.

Dental Light Bulb Replacement

Refer to the *Instructions for Use* that came with your dental light for information on replacing the dental light bulb.

Dental Light Circuit Breaker Location

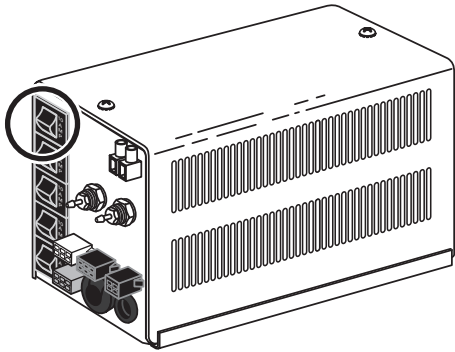

Under abnormal conditions, the dental light circuit breaker interrupts the flow of electricity. If the circuit breaker should trip, reset it by pushing the circuit breaker. The circuit breaker for your dental light is located on the power supply.

Utilities and Shutoff Valves

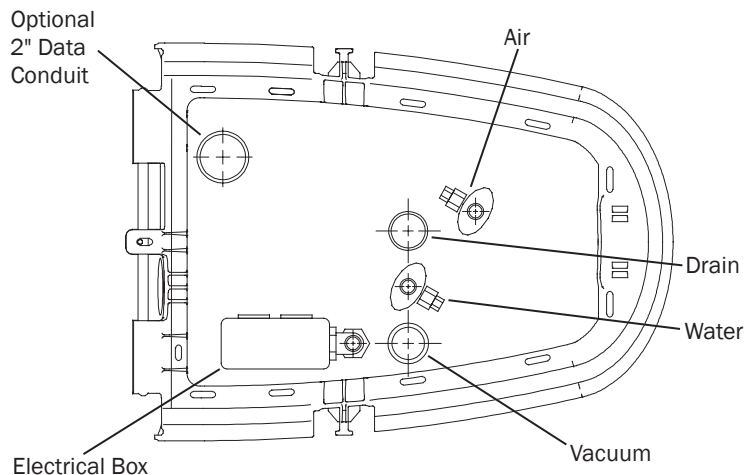

CAUTION When removing or replacing covers, take care not to damage any wiring or tubing. Verify that the covers are secure after replacing them.

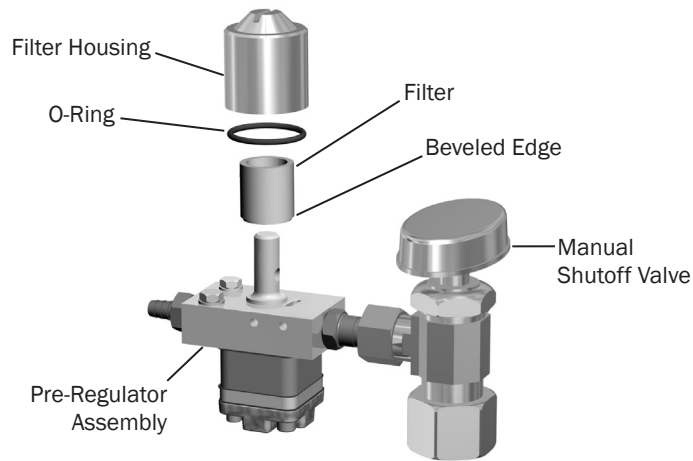

The utilities for A-dec chair-mounted delivery systems are located in the contoured floor box under your chair. To access, lift the cover up and off the floor box frame.

The manual shutoff valves control the air and water to the system. To prevent leaks, leave these valves fully open (turned counterclockwise), except when your system is being serviced.

Air and water pass through separate filters before entering the regulators. Replace these filters when they become clogged and restrict flow.

To check for a clogged water filter:

1. Turn on the master toggle.
2. While watching the cuspidor, press the bowl rinse button. If the bowl rinse water pressure fades or if the water flow stops, replace the water filter.

To replace the filter:

1. Turn off the master toggle and close the shutoff valves (turn clockwise).
2. Bleed the system of air and water pressure by operating the syringe buttons until air and water no longer flow.
3. Using a standard screwdriver, remove the filter housing from the water pre-regulator assembly and remove the filter.
4. Replace the filter if it is clogged or discolored. Install the filter with the beveled edge facing the manifold.



CAUTION To ensure proper operation, install the filter with the beveled edge facing the manifold.

5. Open the shutoff valves, turn on the master toggle, and operate the bowl rinse to remove air from the waterline.

Specifications

Performer Dental Chair

Chair Capacity

Patient Load: 400 lb (182 kg) maximum

Accessory Load: 130 lb (59 kg) maximum

Performer and A-dec 332/333 Delivery Systems

Minimum Air, Water, and Vacuum Service Requirements

Air: 2.5 scfm (71 sL/min) at 80 - 125 psi (550 - 860 kPa) minimum

Water: 1.5 gpm (5.7 L/min) at 60±20 psi (410±140 kPa) minimum

Vacuum:

(wet): 9 scfm (255 sL/min) at 10±2 inches of Hg (34±7 kPa) minimum

(dry): 12 scfm (340 sL/min) at 4.5±1 inches of Hg (16±3.5 kPa) minimum

A-dec HVE/Saliva Ejector Tip Connections

Standard 11 mm HVE: 11 mm (0.433") diameter opening
(for standard HVE tips)

Large bore 15 mm HVE: 15 mm (0.591") diameter opening
(for large bore HVE tips)

Standard 6 mm SE: 6 mm (0.236") diameter opening
(for standard SE tips)



IMPORTANT For chair accessory load capacity, electrical specifications, identification of symbols, and other regulatory requirements, see the *Regulatory Information, Specifications, and Warranty* document (p/n 86.0221.00), which is available in the Document Library at www.a-dec.com.



NOTE Specifications are subject to change without notice. Requirements may vary depending on your location. For more information, contact your authorized A-dec dealer.



 **A-dec Headquarters**

2601 Crestview Drive
Newberg, Oregon 97132
United States
Tel: 1.800.547.1883 within USA/CAN
Tel: +1.503.538.7478 outside USA/CAN
www.a-dec.com

A-dec Australia

Unit 8
5-9 Ricketty Street
Mascot, NSW 2020
Australia
Tel: 1.800.225.010 within AUS
Tel: +61.(0).2.8332.4000 outside AUS

A-dec China

A-dec (Hangzhou) Dental Equipment Co., Ltd.
Building 5, No.528 Shunfeng Road
Tangqi Town, Yuhang District,
Hangzhou, Zhejiang, China 311100
Tel: 400.600.5434 within China
Tel: +86.571.89026088 outside China

A-dec United Kingdom

Austin House
11 Liberty Way
Nuneaton, Warwickshire CV11 6RZ
England
Tel: 0800.ADEC.UK (2332.85) within UK
Tel: +44.(0).24.7635.0901 outside UK

1434



86.0593.00 Rev E
Date of Issue 2021-02-24
Copyright 2021 A-dec, Inc.
All rights reserved.